

Digital and Analog Flow Meters and Controllers

AALBORG

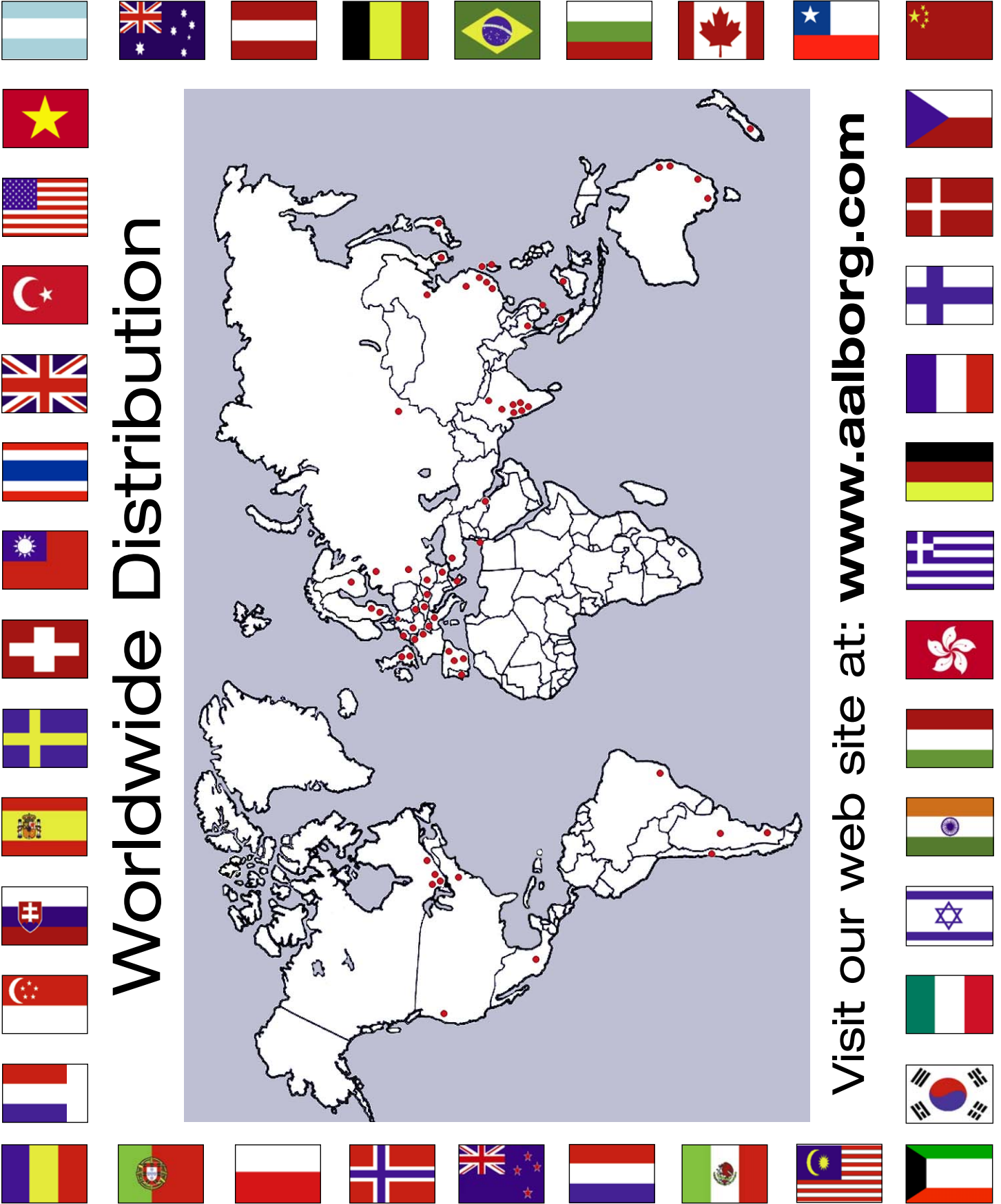



Worldwide Distribution

Visit our web site at: www.aalborg.com



About the Company

Founded in 1972, AALBORG® is well-known throughout the world as a primary manufacturer of precision instrumentation for flow measurement and control.

We operate two divisions:

The Electronics Division produces analog and digital mass flow meters and controllers, as well as a diverse line of wafer and insertion type vortex flow meters for steam, liquid or gases. In addition a line of peristaltic pumps, stepping motor driven valves made in this department are highly useful in processing and OEM applications.

The Variable Area Division manufactures a complete line of glass tube rotameters. These flow meters are available with aluminum, brass, stainless steel or PTFE wetted components. AALBORG® also manufactures a unique line of PFA tube meters for ultrapure or corrosive applications. Precision barstock stainless steel or brass needle valves, as well as PTFE valves, are also manufactured in this division.

NIST Traceable

NIST traceable flow meter calibrations are performed in our state of the art laboratories.

Technical Assistance

Technical Assistance is readily available. Customers are invited to contact the company or our distributors to discuss individual requirements. OEM applications are welcome.

ISO9001/2008 Certification

AALBORG® has been ISO 9001 certified since April of 1995. We are very proud of the design features and the exceptionally high quality for which our products which have been known since 1972. It is our policy that through strict enforcement of exacting manufacturing standards the AALBORG® brand name continues to be associated with a reputation of high quality and reliability. Our products are backed by meticulous innovative engineering combined with efficient manufacturing practices and a highly skilled work force guaranteeing total customer satisfaction.

Our Mission

It is the policy of AALBORG® to develop, produce and deliver products and services which consistently conform to or exceed customer requirements.

Our commitment is to provide cutting-edge technology combined with a sincere desire to serve our customers and produce the highest quality products attainable.

Table of Contents

CAL

Calibrations and Services



Page 1

GFM

Mass Flow Meters



Page 10

XFM

Digital Mass Flow Meters



Page 15

GFC

Mass Flow Controllers



Page 21

TIO

Totalizer Input/Output Flow Monitor/Controller



Page 27

DFC

Digital Mass Flow Controllers



Page 31

DFM

Multi-Parameter Digital Mass Flow Meters



Page 39

AFC

Analog Mass Flow Controllers



Page 45

SDPROC

Microprocessor Driven Command Modules



Page 51

PWM

Paddle Wheel Flow Meters



Page 55

PWE

Digital Paddle Wheel Flow Meter



Page 56

VX

Vortex Flow Meters



Page 61

PSV

Liquid and Gas Flow Regulators



Page 82

SMV

Stepping Motor Valves



Page 87

CON

Conversion Factors

Page 89

NIST Traceable Calibrations

Our laboratories are fully equipped to perform NIST traceable flow calibrations for Rotameters, Mass Flow instruments and many other flow products.

We also offer calibration services on equipment and instrumentation of other manufacturers' products. Our technicians are trained and certified and our Laboratory is equipped to calibrate Molboxes. In addition, our laboratory can calibrate NIST traceable approved "In-House" equipment to certify our primary calibration devices. We also calibrate and certify customers' Molboxes. For fast cost effective service please contact our customer service department.

Compliance Qualifications

Extensive set of Molbox/Molblocs ensure conveniently overlapping calibration ranges.

- ANSI/NCSL Z540-1-1994
- ISO9001/2008 CERTIFIED
- MIL-STD-456624A

ISO/IEC17025 general requirements for the competence of testing and calibration laboratories.

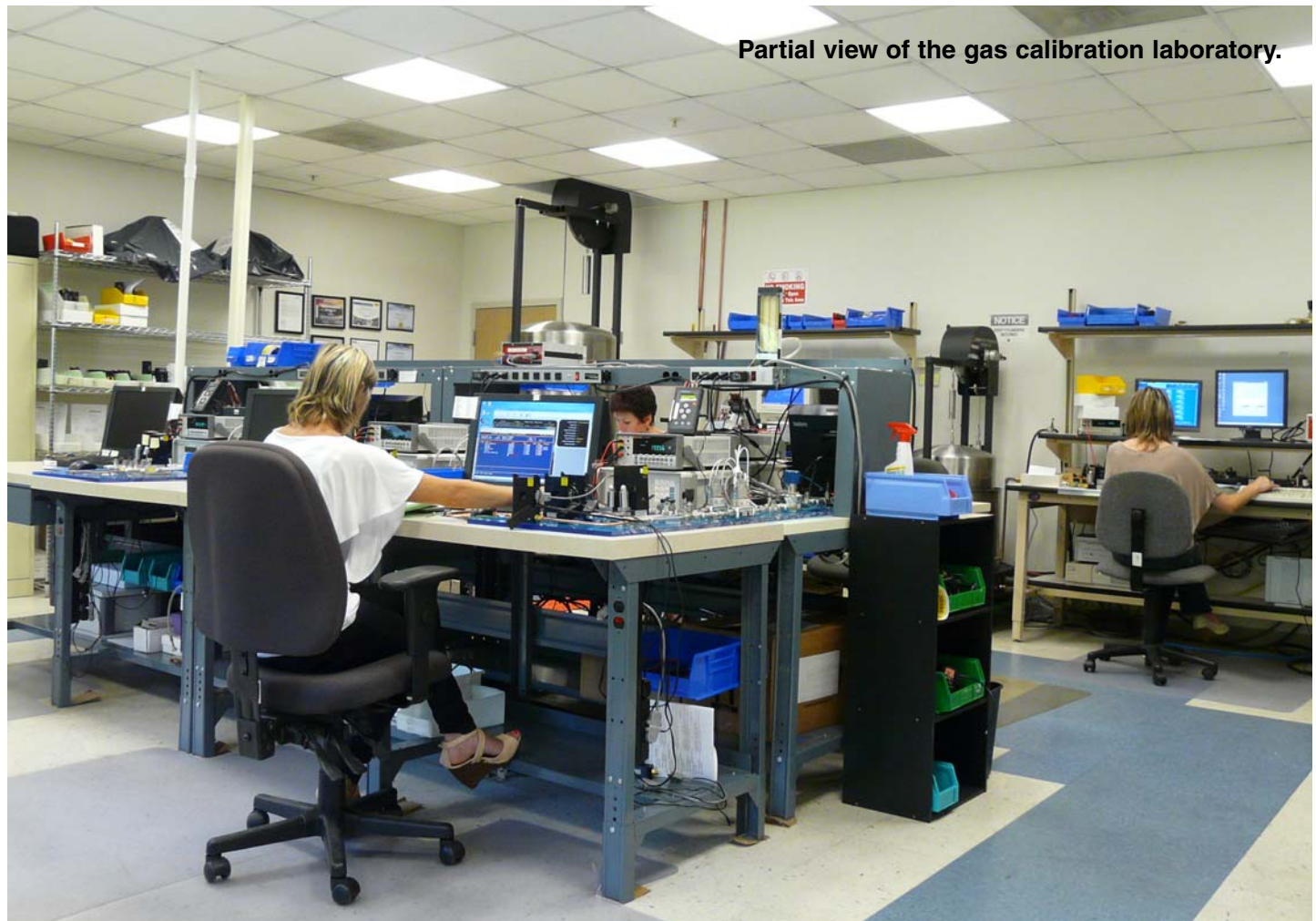

Partial view of the gas calibration laboratory.

Technicians calibrating Mass Flow Controllers using Bell Provers and Molbox/Molblocs technology.

Close-up view of Molbox/Molblocs equipment supported by COMPASS software for calibrating GFM flow meters.

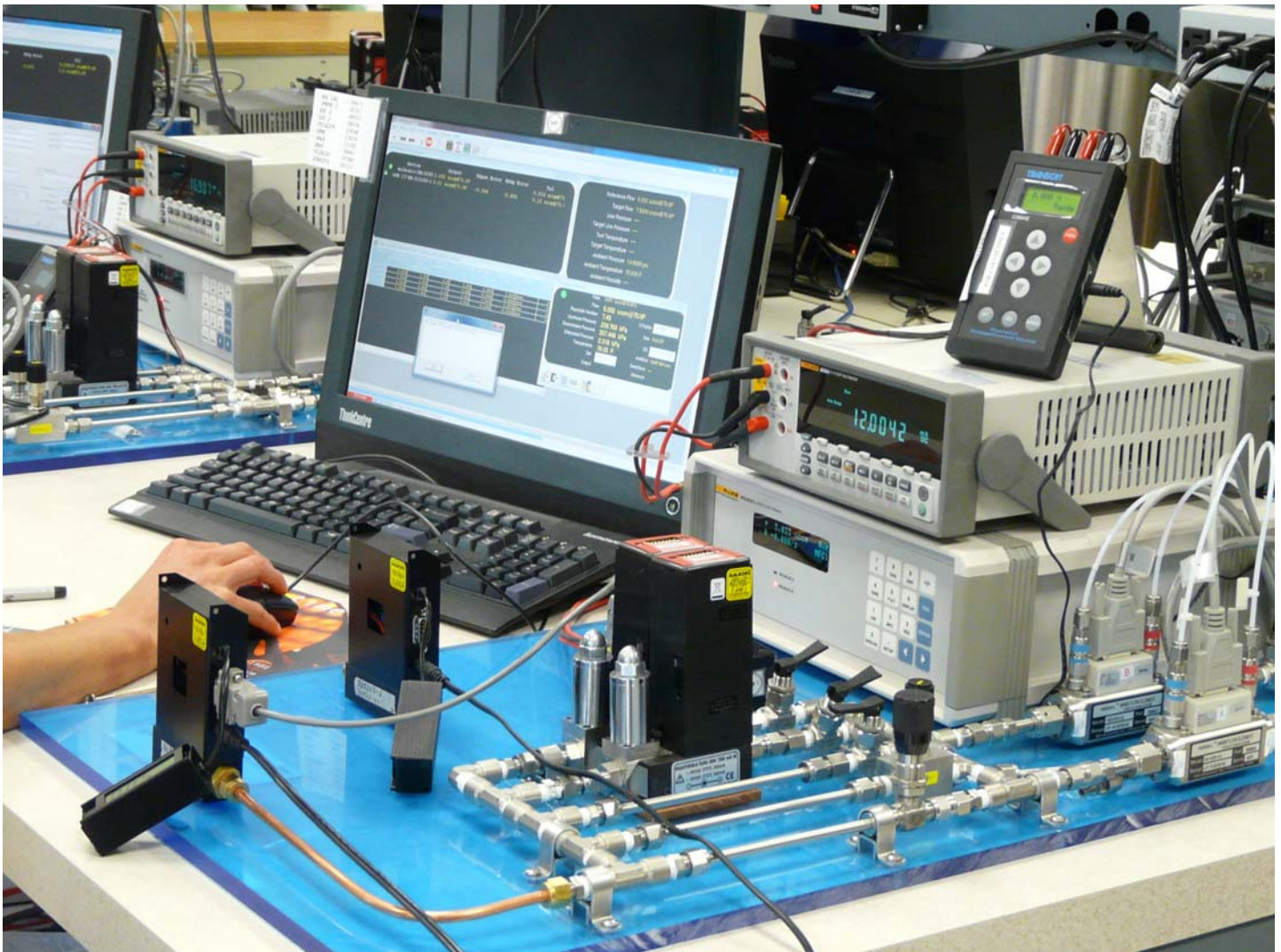

Link for an explanation how to use Molbox/Molblocs method of calibrations of flow meters and controllers.

<http://www.youtube.com/watch?v=FVDqrW5y70A>

Pressure Limits Of Calibrations

Up to 500 PSIG for routine gases (Air, N2, He and Ar) with a maximum flow of 250 L/min. Up to 80 PSIG for Air, with a maximum flow of 1000 L/min.

- Calibrations are performed at standard (STP) conditions (70 °F/21.1 °C and 14.7 psia/1 atm abs).
- Gas calibrations for up to 1000 L/min and water calibrations up to 4 L/min available.
- Calibrated to NIST traceable standards.



Bell prover used by technician in calibrating high flow capacity flow meter.

Terminal shown for low-flow Flow Controller calibration supported by Aalborg SDPROC software.



Piston Gauge, model 7601 with gas operated, gas lubricated piston-cylinder module. It supports definition of pressure against a vacuum reference.



OPERATING MODES:

Gauge, Absolute and Differential.

OVERALL SPECIFICATION FOR PRESSURE MEASUREMENT:

Sensitivity: 0.02Pa +0.5 ppm

Reproducibility: +/-4 ppm

Measurement Uncertainty (k=2): +/- (0.5Pa + 20 ppm)

SUITABLE FOR MOLBOX 1+ A350/A700

Our gas calibration laboratory has NIST traceable approved in-house equipment to certify our calibration devices. Molbox/Molblocs based calibration for GFC Flow Controller.

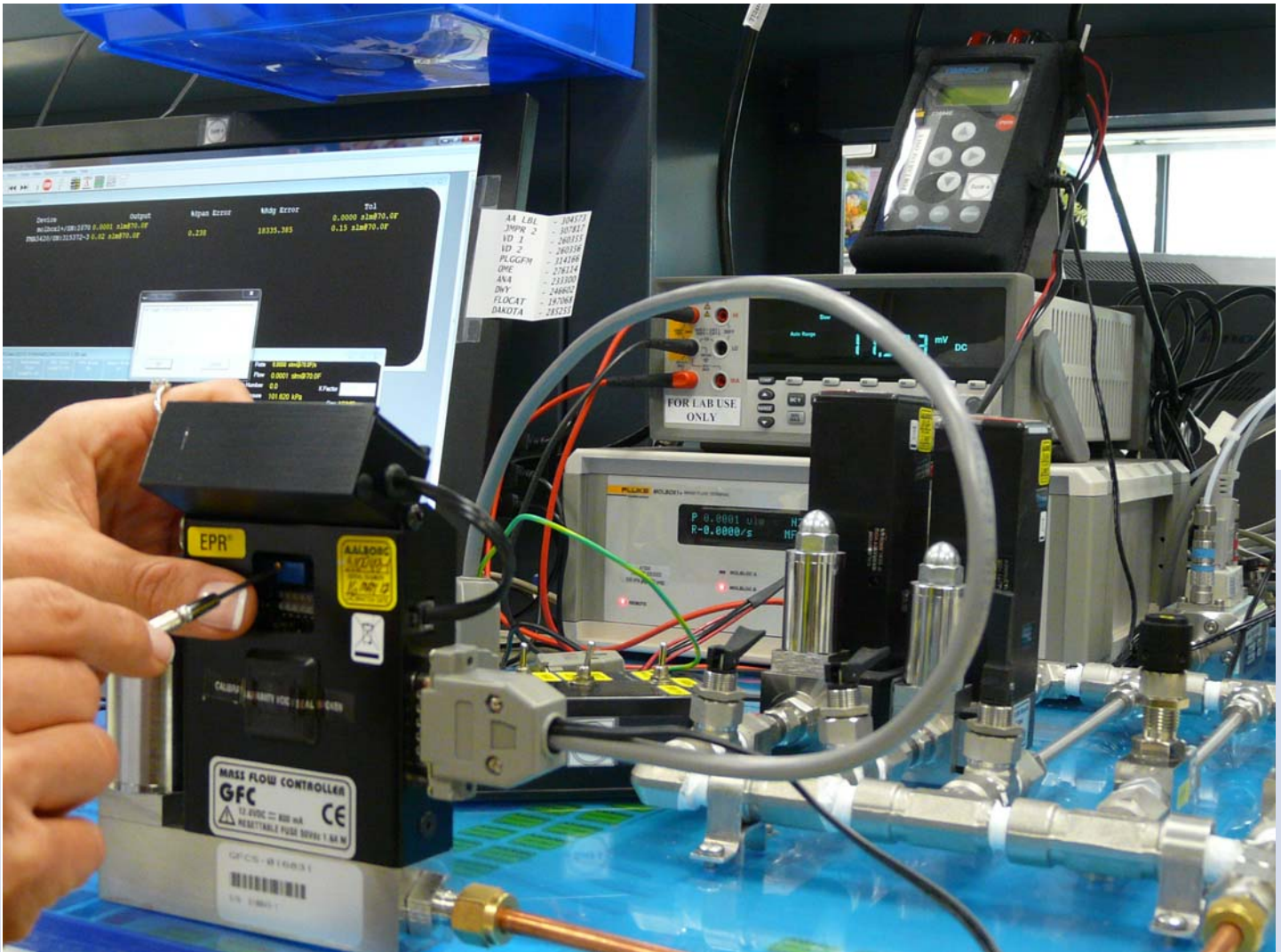

Close-up view of NIST traceable calibration of Flow Controller.

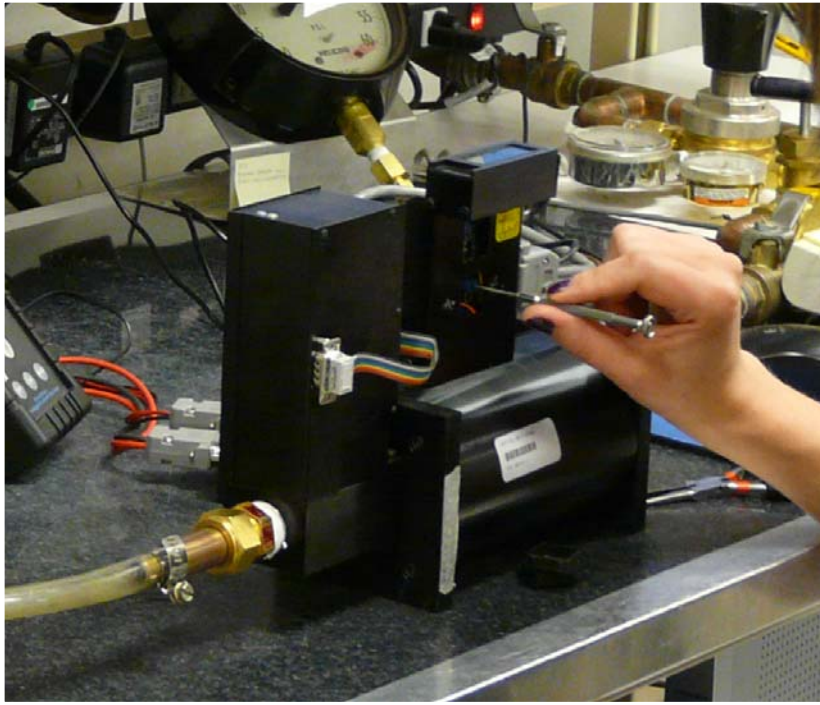

Gas flow calibration laboratory is capable of performing calibrations from 1 mL/min to 1000 L/min at 21.1 °C /101.325 kPa (70 °F, 14.69 PSI abs).



According to principles of ISO-17025 calibrations are performed based on 4 to 1 uncertainty ratio.



Specialized software applied to calibration of Flow Meter.

ASIAN SERVICE FACILITY

Authorized Repair and Service Facility
for Aalborg Thermal Mass Flow Systems

**AALBORG - Beijing Comity
MEASURE & CONTROL CO.**

Floor 1 Tower B Jindayuan Office Building
Xisanqi, Hai Dian District, Beijing, China

Phone: 86-10-6295-0464, 86-10-6295-0465
Fax: 86-10-6295-0466
Website: <http://www.comity-tec.com>



EUROPEAN SERVICE FACILITY

Authorized Repair and Service Facility
for Aalborg Thermal Mass Flow Systems

**AALBORG - ANALYT-MTC
MESSTECHNIK GMBH**

Klosterrunsstraße 18 P.O. Box 1321
Müllheim D-79379 Germany

Telefon: +49 (0)7631 5545
Fax: +49 (0)7631 14740
Website: www.analyt-mtc.de
e-mail: info@analyt_mtc.de



Typical Bell Prover
used for NIST traceable calibrations



Design Features

- Rigid metallic construction.
- Maximum pressure of 1000 psig (70 bars).
- Leak integrity 1×10^{-9} of helium.
- NIST traceable certification.
- Built-in tiltable LCD readout.
- 0-5 Vdc and 4-20 mA signals.
- Circuit protection.
- Can be used as a portable device.
- Engineering units or 0 to 100% displays.
- TIO Totalizer option.

Typical Aluminum GFM Mass Flow Meter



Principles of Operation

Metered gases are divided into two laminar flow paths, one through the primary flow conduit, and the other through a capillary sensor tube. Both flow conduits are designed to ensure laminar flows and therefore the ratio of their flow rates is constant.

Two precision temperature sensing windings on the sensor tube are heated, and when flow takes place, gas carries heat from the upstream to the downstream windings. The resultant temperature differential is proportional to the change in resistance of the sensor windings.

A Wheatstone bridge design is used to monitor the temperature dependent resistance gradient on the sensor windings which is linearly proportional to the instantaneous rate of flow.

Output signals of 0 to 5Vdc and 4 to 20mA are generated indicating mass molecular based flow rates of the metered gas.

Flow rates are unaffected by temperature and pressure variations within stated limitations.

General Description

Compact, self-contained GFM mass flow meters are designed to read flow rates of gases. The rugged design coupled with instrumentation grade accuracy provides versatile and economical means of flow measurement.

Aluminum or stainless steel models with readout options of either engineering units (standard) or 0 to 100 percent displays are available.

The mechanical layout of the design includes an LCD readout built into the top of the transducer. This readout module is tiltable over 90 degrees to provide optimal reading comfort. It is connected to the transducer by a standard modular plug, and is also readily removable for remote reading installations.

GFM 57, 67 and 77
High Flow Mass Flow Meters



TABLE 1 - SPECIFICATIONS FOR GFM

ACCURACY:	GFM 17, 37 and 47: ±1.0% of full scale. GFM 57, 67 and 77: ±1.5% of full scale. OPTIONAL ENHANCED ACCURACY: ±1.0% of full scale.
CALIBRATIONS:	Performed at standard conditions [14.7 psia (101.4 kPa) and 70 °F (21.1 °C)] unless otherwise requested.
REPEATABILITY:	±0.25% of full scale.
RESPONSE TIME:	Generally 2 seconds to within ±2% of actual flow rate over 25 to 100% of full scale.
TEMPERATURE COEFFICIENT:	0.15% of full scale / °C.
PRESSURE COEFFICIENT:	0.01% of full scale / psi (0.07 bar).
MAXIMUM PRESSURE DROP:	See Table 3.
GAS and AMBIENT TEMP.:	32 °F to 122 °F (0 °C to 50 °C). 14 °F to 122 °F (-10 °C to 50 °C) - Dry gases only.
OUTPUT SIGNALS:	Linear 0-5 Vdc. 1000 ohms min. load impedance and 4-20 mA 0-500 Ohms loop resistance..
TRANSDUCER INPUT POWER:	Universal +12 to +26 VDC, 200 mA maximum.
TIME CONSTANT:	800 ms.
GAS PRESSURE:	1000 psig (70 bars) maximum GFM 17, 37, 47. 20 psig (1.4 bars) optimum. 500 psig (34.5 bars) GFM 57, 67, 77. 20 psig (1.4 bars) optimum.
** MATERIALS IN FLUID CONTACT:	a. Aluminum models GFM Series: anodized aluminum, 316 stainless steel, brass and Viton® O-rings. b. Stainless steel models GFM17S, 37S,47S, 57S, 67S and 77S: 316 stainless steel and Viton® O-rings. Optional O-rings: Buna®, EPR and Kalrez®.
ATTITUDE SENSITIVITY:	No greater than +15 degree rotation from horizontal to vertical; standard calibration is in horizontal position.
CONNECTIONS:	GFC 17: 1/4" compression fittings. <i>Optional:</i> 6mm, 3/8" and 1/8" compression fittings or 1/4" VCR®. GFC 37: 1/4" compression fittings. <i>Optional:</i> 6mm and 3/8" compression fittings or 1/4" VCR®. GFM 47: 3/8" compression fittings. GFM 57: 3/8" compression fittings. GFM 67: 1/2" compression fittings. GFM 77: 3/4" FNPT fittings or 3/4" compression fittings.
LEAK INTEGRITY:	1 x 10 ⁻⁹ sml/sec of helium maximum to the outside environment.
CE COMPLIANT:	EN 55011 class 1, class B; EN50082-1.

**The selection of materials of construction, is the responsibility of the customer. The company accepts no liability.

Transducers without LCD readout are offered for OEM applications.

GFM mass flow meters are available with flow ranges from 10 mL/min to 1000 L/min N₂. Gases are connected by means of 1/4" 3/8" 1/2" compression fittings and 3/4" FNPT fittings. Optional fittings are available. These meters may be used as bench top units or mounted by means of screws in the base.

Transducer power supply ports are fuse and polarity protected.

TABLE 2 - FLOW RANGES FOR GFM

GFM 17 LOW FLOW MASS FLOW METERS	
CODE	mL/min [N ₂]
01	0 to 10
02	0 to 20
03	0 to 50
04	0 to 100
05	0 to 200
06	0 to 500
CODE	L/min [N ₂]
07	0 to 1
08	0 to 2
09	0 to 5
10	0 to 10
GFM 37 MEDIUM FLOW MASS FLOW METERS	
11	0 to 15
30	0 to 20
31	0 to 30
32	0 to 40
33	0 to 50
GFM 47 HIGH FLOW MASS FLOW METERS	
40	0 to 60
41	0 to 80
42	0 to 100
GFM 57 HIGH FLOW MASS FLOW METERS	
50	0 to 200
GFM 67 HIGH FLOW MASS FLOW METERS	
60	0 to 500
GFM 77 HIGH FLOW MASS FLOW METERS	
70	0 to 1000

Leak Integrity

1 x 10⁻⁹ smL/sec of helium max to outside environment.

TABLE 3 - MAXIMUM PRESSURE DROP FOR GFM

MODEL	FLOW RATE [liters/min]	MAXIMUM PRESSURE DROP		
		[mm H ₂ O]	[psid]	[mbar]
GFM 17	up to 10	25	0.04	2.5
	20	300	0.44	30
GFM 37	30	800	1.18	81
	40	1480	2.18	150
	50	2200	3.23	223
GFM 47	60	3100	4.56	314
	80	4422	6.5	448
	100	5500	8.08	557
GFM 57	200	2720	4.0	280
GFM 67	500	3400	5.0	340
GFM 77	1000	6120	9.0	620

TABLE 4 - ACCESSORIES FOR GFM

POWER SUPPLY - BATTERY PACK - CABLES	
PS-GFM-110NA-2	Power Supply, 110 V / 12 Vdc /North America
PS-GFM-110NA-4	Power Supply, 110 V / 24 Vdc /North America
PS-GFM-230EU-2	Power Supply, 220 V / 12 Vdc /Europe
PS-GFM-230EU-4	Power Supply, 220 V / 24Vdc /Europe
PS-GFM-240UK-2	Power Supply 240 V / 12 Vdc /United Kingdom
PS-GFM-240UK-4	Power Supply 240 V / 24 Vdc /United Kingdom
PS-GFM-240AU-2	Power Supply 240 V / 12 Vdc /Australia
PS-GFM-240AU-4	Power Supply 240 V / 24 Vdc /Australia
BP110	Battery Pack, 110 V (includes case)
BP220	Battery Pack, 220 V (includes case)
CBL-D4	Cable with 9-pin D-connector, (4 - 20 mA)
CBL-D5	Cable with 9-pin D-connector, (0 to 5 Vdc)
17/3RC	17/3RC Remote cable, 3 ft long
17/R	17/R Remote LCD readout with 3 ft long cable
TIO-LAA2	Totalizer I/O Monitor, RS-232 Digital Interface
TIO-LAA5	Totalizer I/O Monitor, RS-485 Digital Interface
KIT-TM-DD	GFM Flow Meter Mounting Kit with Two 9 Pin D-Connectors

For Totalizer Input/ Output Flow Monitor/ Controller options see page 26.

GFM Mass Flow Meters

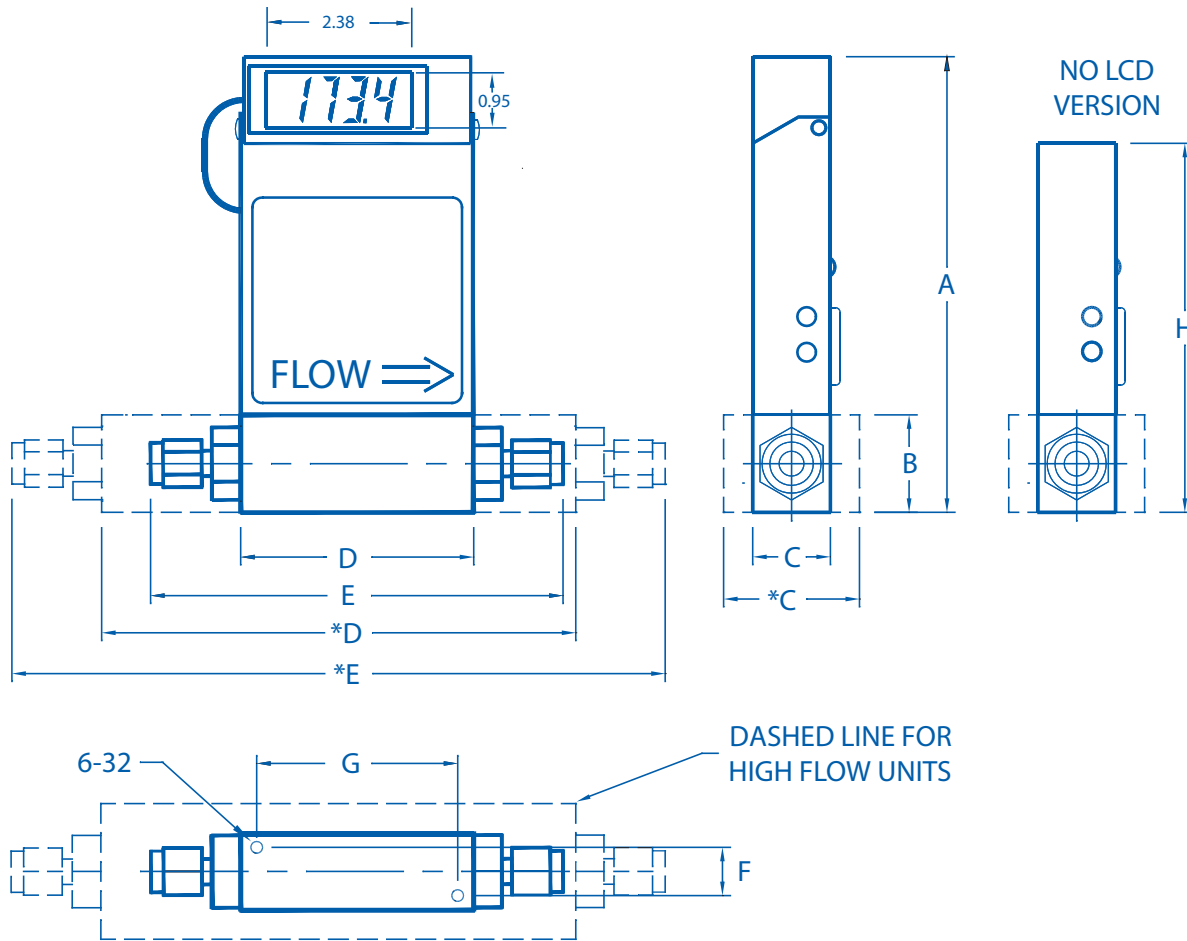

TABLE 5 - DIMENSIONS FOR GFM

MODEL	CONNECTION Compression Fitting (except model GFM 77)	DIMENSION (INCH)							NO LCD
		LCD VERSION							
		A	B	C/*C	D/*D	E/*E	F	G	H
GFM 17	1/4" Tube O Diameter	5.60	1.00	1.00	3.00	5.02	0.69	2.69	4.50
GFM 37	1/4" Tube O Diameter	5.98	1.37	1.25	4.13	6.15	0.69	2.69	4.88
GFM 47	3/8" Tube O Diameter	5.98	1.37	1.25	4.13	6.27	0.69	2.69	4.88
GFM 57	3/8" Tube O Diameter	6.60	2.00	1.75	6.69	8.83	0.99	4.69	5.50
GFM 67	1/2" Tube O Diameter	7.60	3.00	3.00	7.25	9.67	2.250	6.750	6.50
GFM 77	3/4" NPT Female	8.60	4.00	4.00	7.30	-	3.000	6.800	7.50

For Specific Flow Ranges Contact Aalborg Customer Service Department.

GFM	MODEL
MAX FLOW (N ₂)	
17	10 L/min
37	50 L/min
47	100 L/min
57	200 L/min
67	500 L/min
77	1000 L/min
MATERIAL	
A	Aluminum
S	Stainless Steel
SEALS	
V	Viton®
B	Buna®
E	EPR
T	PTFE / Kalrez®
FITTINGS	
A	1/4" Compression
B	1/8" Compression
C	1/4" VCR®
D	3/8" Compression
E	1/2" Compression
F	3/4" FNPT
G	3/4" Compression
H	6mm Compression
MODEL	
A	GFM 17, 37
B	GFM 17
C	GFM 17, 37
D	GFM 17, 37, 47, 57
E	GFM 67
F	GFM 77
G	GFM 77
H	GFM 17, 37
DISPLAY	
N	No Display
L	LCD Readout
POWER	
6	Universal +12 to +26 VDC
OUTPUT SIGNAL	
A	0-5 VDC
B	4-20 mA
DIGITAL INTERFACE	
0	None

GFM 17 S — V A L 6 — A 0

EXAMPLE: GFM17S-VAL6-A0 5 L/min [N₂] 20 psig
SPECIFY: FLOW RANGE, GAS and PRESSURE *n.a. = not applicable.

GFM17 stainless steel, Viton® seals, 1/4" compression fittings, display, 12 to 26 Vdc power, 0-5 Vdc, output signal, no digital interface.



Design Features

- Supports up to 23 Engineering Units (including User Defined).
- Stores calibration data for up to 10 gases.
- Programmable Totalizer indicates total gas quantity.
- High and low gas flow Alarm limits with preset delay interval.
- Two sets of user-programmable electromechanical SPDT relays with latch option.
- User-selectable analog 0-5 Vdc or 4-20mA outputs.
- Internal Conversion factors for up to 32 gases.
- Digital Interface (RS-232 / RS-485, Profibus DP available).
- Multi-Drop Capability of up to 256 units (RS-485 option).
- Optional Profibus DP interface with I&M functionality.
- Automatic sensor zero offset adjustment (via digital interface or local push button).
- Self-Diagnostic Tests.
- Local 2 x 16 characters LCD display* with adjustable back light (optional).

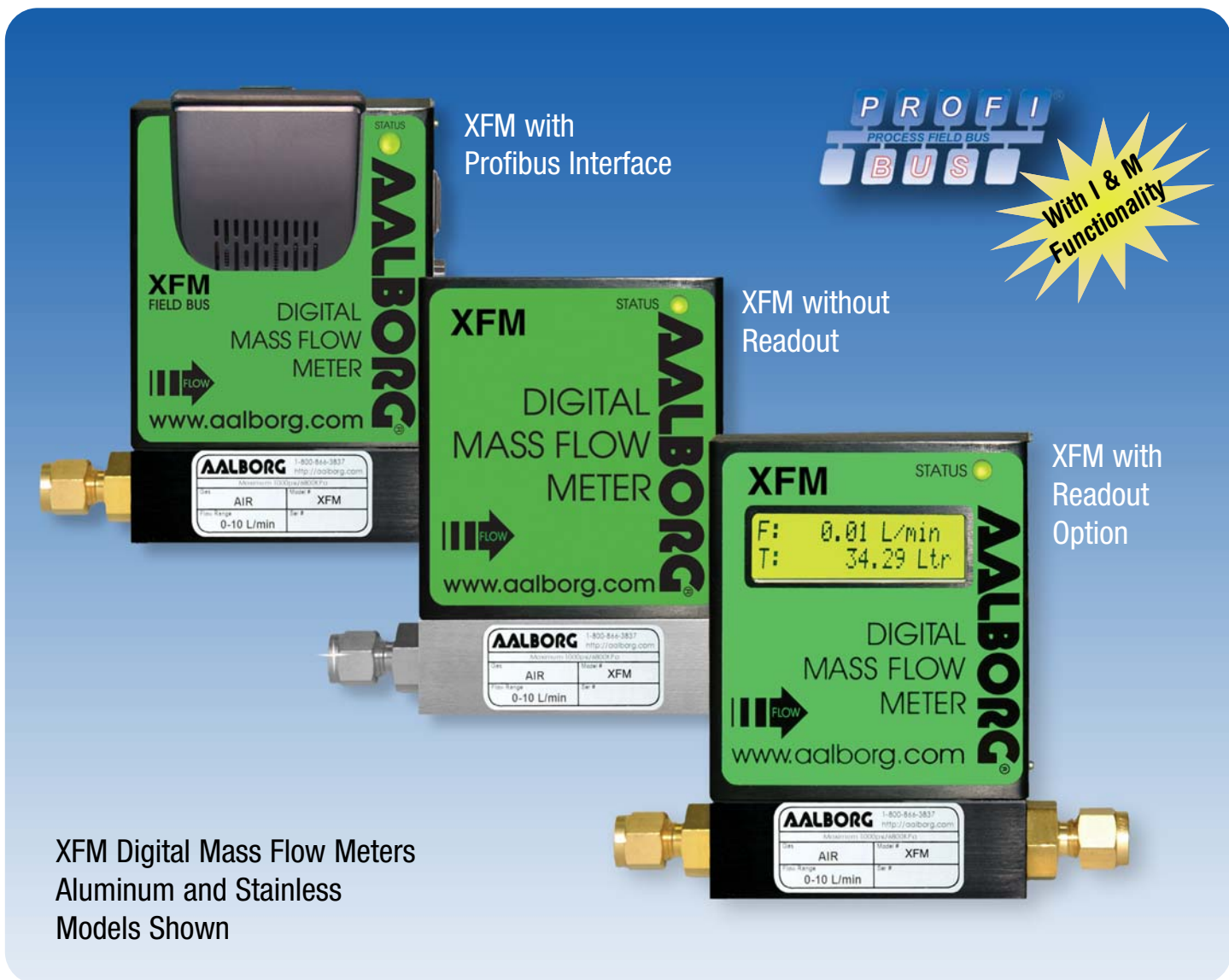

XFM Digital Mass Flow Meters
Aluminum and Stainless
Models Shown

* LCD display is not available for Profibus DP interface option.

XFM Digital Mass Flow Meters

The flow rate can be displayed in 23 different volumetric flow or mass flow engineering units including user specific. Flow meters can be programmed remotely via RS-232 /RS-485 or optional Profibus DP interface.

XFM flow meters support various functions including: programmable flow totalizer, high and low flow alarm, automatic zero adjustment, 2 relay outputs, jumper selectable 0-5 Vdc or 4-20 mA analog outputs, status LED diagnostic, capable to store calibration for up to 10 different gases, internal or user-specific K-factors. Optional local 2 x 16 characters LCD display* with adjustable back light provides Flow, Total and diagnostic reading simultaneously.

Principle Of Operation

The stream of gas entering the Mass Flow transducer is split by shunting a small portion of the flow through a capillary stainless steel sensor tube. The remainder of the gas flows through the primary flow conduit. The geometry of the primary conduit and the sensor tube are designed to ensure laminar flow in each branch. According to principles of fluid dynamics, the flow rates of a gas in the two laminar flow conduits are proportional to one another. Therefore, the flow rates measured in the sensor tube are directly proportional to the total flow through the transducer. In order to sense the flow in the sensor tube, heat flux is introduced at two sections of the sensor tube by means of precision-wound heater sensor coils. Heat is transferred through the thin wall of the sensor tube to the gas flowing inside. As gas flow takes place, heat is carried by the gas stream from the upstream coil to the downstream coil windings.

The resultant temperature dependent resistance differential is detected by the electronic control circuit. The measured temperature gradient at the sensor windings is linearly proportional to the instantaneous rate of flow taking place. An output signal is generated that is a function of the amount of heat carried by the gases to indicate mass molecular based flow rates. Additionally, the XFM model Mass Flow Meter incorporates a Precision Analog Microcontroller (ARM7TDMI® MCU) and non-volatile memory that stores all hardware specific variables and up to 10 different calibration tables.

* LCD display is not available for Profibus DP interface option.

Interface

The digital RS485 or RS-232 interface (optional Profibus DP interface is available) provides access to applicable internal data including: flow, CPU temperature, auto zero, totalizer and alarms settings, gas table, conversion factors and engineering units selection, dynamic response compensation and linearization table adjustment. The analog interface provides 0 to 5Vdc or 4 to 20 mA (jumper selectable) outputs for flow reading.

Auto Zero

The XFM supports automatic sensor zero offset adjustment which can be activated locally via the maintenance push button or remotely via digital interface. The auto zero feature necessitates a condition of absolutely no flow through the meter during the adjustment process. Provisions are made to either start, read, or save the current auto zero value via digital commands.

Totalizer

The total volume of the gas is calculated by integrating the actual gas flow rate as a function of time.

THE DIGITAL INTERFACE COMMANDS ARE PROVIDED TO:

- SET THE TOTALIZER TO ZERO.
- START THE TOTALIZER AT A PRESET FLOW.
- ASSIGN ACTION AT A PRESET TOTAL VOLUME.
- START/STOP TOTALIZING THE FLOW.
- READ TOTALIZER.

Totalizer conditions become true when the totalizer reading and the "Stop at Total" volumes are equal. In addition, the provision is made to automatically disable Totalizer during sensor warm up period.

Flow Alarm

High and Low gas flow ALARM limits can be preprogrammed via digital interface. ALARM conditions become true when the current flow reading is equal or higher/lower than corresponding values of high and low alarm levels. Alarm action can be assigned with preset delay interval (0-3600 seconds) to activate the contact closer (separate for High and Low alarm). Latch Mode control feature allows each relay to be latched on or follow the corresponding alarm status.

TABLE 6 - SPECIFICATIONS

FLOW MEDIUM:	Please note that XFM Mass Flow Meters are designed to work only with clean gases. Never try to measure flow rates of liquids with any XFM.
CALIBRATIONS:	Performed at standard conditions [14.7 psia (101.4 kPa) and 70 °F (21.1°C)] unless otherwise requested.
ENVIRONMENTAL (PER IEC 664):	Installation Level II; Pollution Degree II.
FLOW ACCURACY	±1% of FS at calibration temperature and pressure.
REPEATABILITY:	±0.25% of full scale.
FLOW TEMPERATURE COEFFICIENT:	0.15% of full scale/ °C or better.
FLOW PRESSURE COEFFICIENT:	0.01% of full scale/psi (6.895 kPa) or better.
FLOW RESPONSE TIME:	600ms time constant; approximately 2 seconds to within ±2% of set flow rate for 25% to 100% of full scale flow.
MAXIMUM GAS PRESSURE:	500 psig (3447 kPa gauge).
MAXIMUM PRESSURE DROP:	0.18 PSID (at 10 L/min flow). 4 psi (at 50 L/min flow). See Table 9 for pressure drops associated with various models and flow rates.
GAS AND AMBIENT TEMPERATURE:	32 °F to 122 °F (0 °C to 50 °C). 14 °F to 122 °F (-10 °C to 50 °C) - Dry gases only.
RELATIVE GAS HUMIDITY:	Up to 70%.
LEAK INTEGRITY:	1 x 10 ⁻⁹ smL/sec He maximum to the outside environment.
ATTITUDE SENSITIVITY:	Deviation of up to 1% from stated accuracy, after re-zeroing.
OUTPUT SIGNALS:	Linear 0-5 Vdc (3000 ohms min load impedance); Linear 4-20 mA (500 ohms maximum loop resistance). Maximum noise 20mV peak to peak (for 0-5 Vdc output).
CONNECTIONS:	XFM 17 and 37: 1/4" compression fittings. Optional: 6mm compression, 1/4" VCR®, 3/8" or 1/8" compression fittings. XFM 47: 3/8" compression fittings.
TRANSDUCER INPUT POWER:	11 to 26 Vdc, 100 mV maximum peak to peak output noise. POWER CONSUMPTION: +12Vdc (200 mA maximum); +24Vdc (100 mA maximum); Circuit board have built-in polarity reversal protection, 300mA resettable fuse provide power input protection.
WETTED MATERIALS:	Aluminum Models: Anodized aluminum, brass, 316 stainless steel, Viton® O-rings. Stainless Steel Models: 316 stainless steel, Viton® O-rings. Optional O-ring Materials: Buna-N®, EPR® (Ethylene Propylene), or Kalrez®.
CAUTION:	Aalborg makes no expressed or implied guarantees of corrosion resistance of mass flow meters as pertains to different flow media reacting with components of meters. It is the customers' sole responsibility to select the model suitable for a particular gas based on the fluid contacting (wetted) materials offered in the different models.
DISPLAY:	*Optional local 2x16 characters LCD with adjustable backlight (2 lines of text).
CALIBRATION OPTIONS:	Standard is one 10 points NIST traceable calibration. Optional, up to 9 additional calibrations may be ordered at additional charge.
CE COMPLIANCE:	EMC Compliance with 89/336/EEC as amended. Emission Standard: EN 55011:1991, Group 1, Class A Immunity Standard: EN 55082-1:1992.

* LCD display is not available for Profibus DP interface option.

Multi-Gas Calibration

The XFM is capable of storing primary calibration data for up to 10 gases. This feature allows the same XFM to be calibrated for multiple gases while maintaining the rated accuracy on each.

Conversion Factors

Conversion factors for up to 32 gases are stored in the XFM. In addition, provision is made for a user-defined conversion factor. Conversion factors may be applied to any of the ten gas calibrations via digital interface commands.

Contact Closure

Two sets of electromechanical SPDT relay outputs are provided to actuate user-supplied equipment.

These are programmable via digital interface such that the relays can be made to switch when a specified event occurs (e.g. when a low or high flow alarm limit is exceeded or when the totalizer reaches a specified value) or may be directly controlled by user.

TABLE 7 - STANDARD FLOW CAPACITIES FOR XFM

XFM 17		XFM 37	XFM 47
mL/min [N ₂]	L/min [N ₂]	L/min [N ₂]	L/min [N ₂]
5	1	20	60
10	2	30	80
20	5	40	100
50	10	50	
100			
200			
500			

Leak Integrity

1 x 10⁻⁹ smL/sec of Helium maximum to the outside environment.

Engineering Units

The measured gas flow and associated totalizer data are scaled directly in engineering units via the digital interface.

THE FOLLOWING 23 UNITS OF MEASURE ARE SUPPORTED:

TABLE 8 - UNITS OF MEASURE FOR XFM

NUMBER	INDEX	FLOW RATE ENGINEERING UNITS	TOTALIZER ENGINEERING UNITS	DESCRIPTION
1	0	%	%s	Percent of full scale
2	1	mL/sec	mL	Milliliter per second
3	2	mL/min	mL	Milliliter per minute
4	3	mL/hr	mL	Milliliter per hour
5	4	L/sec	Ltr	Liter per second
6	5	L/ min	Ltr	Liter per minute
7	6	L/hr	Ltr	Liter per hour
8	7	m ³ /sec	m ³	Cubic meter per second
9	8	m ³ / min	m ³	Cubic meter per minute
10	9	m ³ /hr	m ³	Cubic meter per hour
11	10	ft ³ /sec	f ³	Cubic feet per second
12	11	ft ³ /min	f ³	Cubic feet per minute
13	12	ft ³ /hr	f ³	Cubic feet per hour
14	13	g/sec	g	Grams per second
15	14	g/min	g	Grams per minute
16	15	g/hr	g	Grams per hour
17	16	kg/sec	kg	Kilograms per second
18	17	kg/min	kg	Kilograms per minute
19	18	kg/hr	kg	Kilograms per hour
20	19	Lb/sec	Lb	Pounds per second
21	20	Lb/min	Lb	Pounds per minute
22	21	Lb/hr	Lb	Pounds per hour
23	22	User	UD	User defined

TABLE 9 - MAXIMUM PRESSURE DROP FOR XFM

MODEL	FLOW RATE [liters/min]	MAXIMUM PRESSURE DROP		
		[mm H ₂ O]	[psid]	[kPa]
XFM 17	up to 10	130	0.18	1.275
XFM 37	up to 50	2722	4	27.58
XFM 47	up to 100	1974	2.9	20

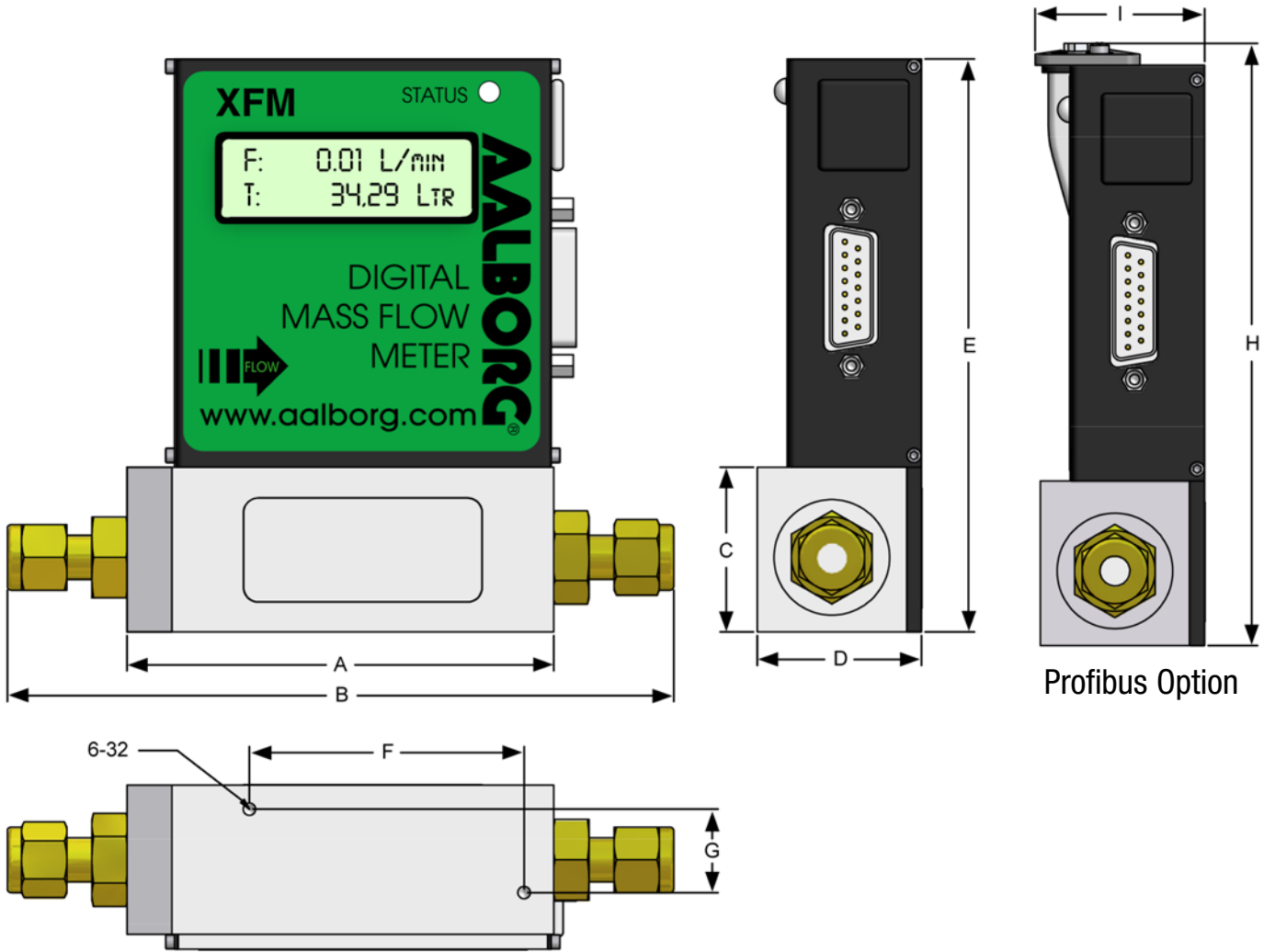

TABLE 10 - DIMENSIONS FOR XFM [INCH]

MODEL	*CONNECTION Compression Fitting (tube OD)	LCD and NO LCD VERSIONS							PROFIBUS CAPABILITY	
		A	B	C	D	E	F	G	H	I
XFM 17	1/4"	3.09	5.10	1.00	1.12	4.42	2.81	0.72	4.67	1.42
XFM 37	1/4"	3.57	5.58	1.37	1.37	4.80	2.30	0.70	5.05	1.42
XFM 47	3/8"	3.57	5.68	1.37	1.37	4.80	2.30	0.70	5.05	1.42

TABLE 11 - DIMENSIONS FOR XFM [MM]

MODEL	*CONNECTION Compression Fitting (tube OD)	LCD and NO LCD VERSIONS							PROFIBUS CAPABILITY	
		A	B	C	D	E	F	G	H	I
XFM 17	1/4"	78.5	129.5	25.4	28.6	112.3	71.4	18.3	118.6	36.0
XFM 37	1/4"	90.7	141.7	34.9	34.9	121.9	58.4	17.8	128.3	36.0
XFM 47	3/8"	90.7	144.3	34.9	34.9	121.9	58.4	17.8	128.3	36.0

* For optional fittings see table 6.



XFM	MODEL
MAX FLOW (N ₂)	
17	10 L/min
37	50 L/min
47	100 L/min
MATERIAL	
A	Aluminum
S	Stainless Steel
SEALS	
V	Viton®
B	Buna®
E	EPR
T	PTFE / Kalrez®
FITTINGS	
A	1/4" Compression
B	1/8" Compression
C	1/4" VCR®
D	3/8" Compression
H	6mm Compression
MODEL	
	XFM 17, 37
	XFM 17
	XFM 17, 37
	XFM 37, 47
	XFM 17, 37
DISPLAY	
N	NO Display
L	LCD Readout
POWER	
6	Universal 11 to 26 VDC
OUTPUT SIGNAL	
A	0-5 VDC
B	4-20 mA
DIGITAL INTERFACE	
2	RS232
5	RS485
9	PROFIBUS

XFM 17 S - V A L 6 - A 2

EXAMPLE: XFM17S-VAL6-A2 5 L/min [N₂] 20 psig

SPECIFY: FLOW RANGE, GAS, and PRESSURE *n.a. = not applicable.

XFM17 stainless steel, Viton® seals, 1/4" compression fittings with LCD readout, 11 to 26 VDC, 0-5 Vdc output signal with RS232 digital interface.

Model GFC thermal Mass Flow Controllers are designed to indicate and control set flow rates of gases.

The GFC combines the characteristics and accuracy of conventional mass flow devices into a unique compact design at low costs previously unattainable.

Each of these controllers incorporates an advanced straight tube sensor in conjunction with flow passage elements constructed of aluminum and brass for non-corrosive gases or 316 stainless steel for corrosive applications. Zero and span adjustments are accessible from the outside of transmitters.

Principles of Operation

Metered gases are divided into two laminar flow paths, one through the primary flow conduit, and the other through a capillary sensor tube. Both flow conduits are designed to ensure laminar flows and therefore the ratio of their flow rates is constant.

Two precision temperature sensing windings on the sensor tube are heated, and when flow takes place, gas carries heat from the upstream to the downstream windings. The resultant temperature differential is proportional to the change in resistance of the sensor windings.

A Wheatstone bridge design is used to monitor the temperature dependent resistance gradient on the sensor windings which is linearly proportional to the instantaneous rate of flow.

Output signals of 0 to 5Vdc and 4 to 20mA are generated indicating mass molecular based flow rates of the metered gas. The combined gas streams flow through a proportionating electromagnetic valve with an appropriately selected orifice. The closed loop control circuit continuously monitors the mass flow output and maintains it at the set flow rate.

Flow rates are unaffected by temperature and pressure variations within stated limitations.

Design Features

- Rigid metallic construction.
- Maximum pressure of 1000 psig (70 bars).
- Leak integrity 1×10^{-9} smL/sec of helium.
- NIST traceable certification.
- Built-in tiltable LCD readout.
- Local or remote setpoint control.
- 0-5 Vdc and 4-20 mA signals.
- Circuit protection.
- TIO Totalizer option.

General Description

Compact, self-contained GFC mass flow controllers are designed to indicate and control flow rates of gases. The rugged design coupled with instrumentation grade accuracy provides versatile and economical means of flow control. Aluminum or stainless steel models with readout options of either engineering units (standard) or 0 to 100 percent displays are available. The built-in electromagnetic valve allows the flow to be set to any desired flow rate within the range of the particular model.



Typical Stainless Steel GFC Mass Flow Controller

BULLETIN EM201412 GFC

Setpoints are controlled either locally or remotely. The valve is normally closed as a safety feature to ensure that gas flow is shut off in case of a power outage. The LCD readout built into the top of the transducer is tiltable over 90 degrees to provide optimal reading comfort. It is connected to the transducer by a standard modular plug, and is readily removable for remote reading installations. Transducers without LCD readout are offered for OEM applications. GFC mass flow controllers are available with flow ranges from 10 mL/min to 1000 L/min N₂. Gases are connected by means of 1/4", 3/8", or optional 1/8" compression fittings and 3/4" FNPT fittings. Optional fittings are available. These controllers may be used as bench top units or mounted by means of screws in the base. Transducer power supply ports are fuse and polarity protected.

Leak Integrity

1 x 10⁻⁹ mL/sec of helium maximum to the outside environment.

TABLE 12 - SPECIFICATIONS

ACCURACY:	ACCURACY %FS				OPTIONAL ENHANCED ACCURACY %FS			
	MODEL:	GFC 17, 37, 47	GFC 57, 67, 77		MODEL:	GFC 57, 67, 77		
	FLOW RANGE:	0-100%	20-100%	0-20%	FLOW RANGE:	20-100%	0-20%	
	ACCURACY:	±1.0%	±1.5%	±3%	ACCURACY:	±1%	±1.0%	REF DATA with ±1%
CALIBRATIONS:	Performed at standard conditions [14.7 psia (101.4 kPa) and 70 °F (21.1°C)] unless otherwise requested.							
REPEATABILITY:	±0.25% of full scale.							
RESPONSE TIME:	Generally 2 seconds to within ±2% of actual flow rate over 25 to 100% of full scale.							
TEMPERATURE COEFFICIENT:	0.15% of full scale / °C.							
PRESSURE COEFFICIENT:	0.01% of full scale / psi (0.07 bar).							
PRESSURE DROP:	See Table 14.							
OPTIMUM GAS PRESSURE:	25 psig (1.73 bars).							
MAX. GAS PRESSURE:	1000 psig (70 bars) maximum GFC 17, 37, 47. 500 psig (34.5 bars) GFC 57, 67, 77.							
TURN DOWN RATIO:	40:1.							
MAX. DIFF. PRESSURE:	50 psi for GFC 17/37/57/67 and 77 (3.4 bars), 40 psi for 47 (2.7 bars).							
GAS and AMBIENT TEMP:	32 °F to 122 °F (0 °C to 50 °C). 14 °F to 122 °F (-10 °C to 50 °C) - Dry gases only.							
**MATERIALS FLUID CONTACT:	a. Aluminum models GFC Series: anodized aluminum, 316 stainless steel, brass and Viton® O-rings. b. Stainless steel models GFC17S, 37S, 47S, 57S, 67S and 77S: 316 stainless steel and Viton® O-rings. Optional O-rings: Buna®, EPR and Kalrez®.							
ATTITUDE SENSITIVITY:	No greater than ±15 degree rotation from horizontal to vertical; standard calibration is in horizontal position.							
OUTPUT SIGNALS:	Linear 0-5 Vdc. (1000 ohms min. load impedance); 4-20 mA (0-500 ohms loop resistance) Max noise ±20mV.							
COMMAND SIGNALS:	Analog 0-5 Vdc or 4-20 mA for remote set point mode; NPN compatible purge /valve off.							
CONNECTIONS:	GFC 17: 1/4" compression fittings. <i>Optional:</i> 6mm, 3/8" and 1/8" compression fittings or 1/4" VCR®. GFC 37: 1/4" compression fittings. <i>Optional:</i> 6mm and 3/8" compression fittings or 1/4" VCR®. GFC 47: 3/8" compression fittings. GFC 57: 3/8" compression fittings. GFC 67: 1/2" compression fittings. GFC 77: 3/4" FNPT fittings. <i>Optional:</i> 3/4" compression fittings.							
LEAK INTEGRITY:	1 x 10 ⁻⁹ smL/sec of helium maximum to the outside environment.							
TRANSDUCER INPUT POWER:	GFC 17, 37 and 47: Universal +12 Vdc to 26 Vdc, 200 mA maximum. GFC 57, 67 and 77: +12 Vdc, 800 mA; +24 Vdc, 650 mA optional.							
CIRCUIT PROTECTION:	Circuit boards have built-in polarity reversal protection. Resettable fuses provide power input protection.							
DISPLAY:	3-1/2 digit LCD, 0.5" high characters.							
CE COMPLIANT:	EN 55011 class 1, class B; EN50082-1.							

***The selection of materials of construction, is the responsibility of the customer. The company accepts no liability.*

TABLE 13 - FLOW RANGES FOR GFC

GFC 17 LOW FLOW MASS FLOW CONTROLLER	
CODE	mL / min [N ₂]
01	0 to 10
02	0 to 20
03	0 to 50
04	0 to 100
05	0 to 200
06	0 to 500
CODE	liters / min [N ₂]
07	0 to 1
08	0 to 2
09	0 to 5
10	0 to 10
GFC 37 MEDIUM FLOW MASS FLOW CONTROLLER	
11	0 to 15
30	20
31	30
32	40
33	50
GFC 47 /57 /67 /77 HIGH FLOW MASS FLOW CONTROLLER	
40	60
41	80
42	100
50	200
60	500
70	1000

TABLE 14 - MAXIMUM PRESSURE DROP FOR GFC

MODEL	FLOW RATE [liters/min]	MAXIMUM PRESSURE DROP		
		[mm H ₂ O]	[psid]	[mbar]
GFC 17	UP to 10	720	1.06	75
	15	2630	3.87	266
	20	1360	2.00	138
GFC 37	30	2380	3.50	241
	40	3740	5.50	379
	50	5440	8.00	551
	60	7480	11.00	758
GFC 47	100	12850	18.89	1302
GFC 57	200	7031	10.00	690
GFC 67	500	8437	12.00	827
GFC 77	1000	10547	15.00	1034

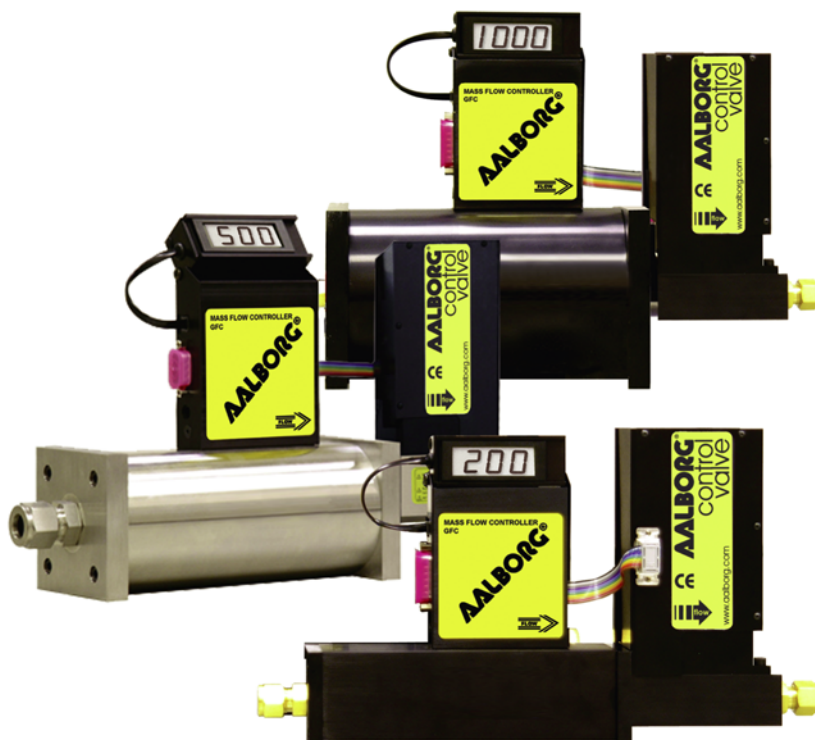

GFC 57, 67 and 77 Series Aluminum and Stainless Mass Flow Controllers

TABLE 15 - ACCESSORIES FOR GFC

POWER SUPPLY - BATTERY PACK - CABLES

PS-GFC-110NA-2	Power Supply, 110 V/12 Vdc /North America
PS-GFC-110NA-4	Power Supply, 110 V/24 Vdc /North America
PS-GFC-230EU-2	Power Supply, 220 V/12 Vdc /Europe
PS-GFC-230EU-4	Power Supply, 220 V/24 Vdc /Europe
PS-GFC-240UK-2	Power Supply 240 V/12 Vdc /United Kingdom
PS-GFC-240UK-4	Power Supply 240 V/24 Vdc /United Kingdom
PS-GFC-240AU-2	Power Supply 240 V/12 Vdc /Australia
PS-GFC-240AU-4	Power Supply 240 V/24 Vdc /Australia
CBL-DGS	Cable, Shielded 15-pin D-connector /end terminated
17/ 3RC	Remote Cable, 3 feet long
17/ R	Remote LCD readout with 3 feet long cable

For Totalizer Input/Output Flow Monitor/ Controller options see page 26.

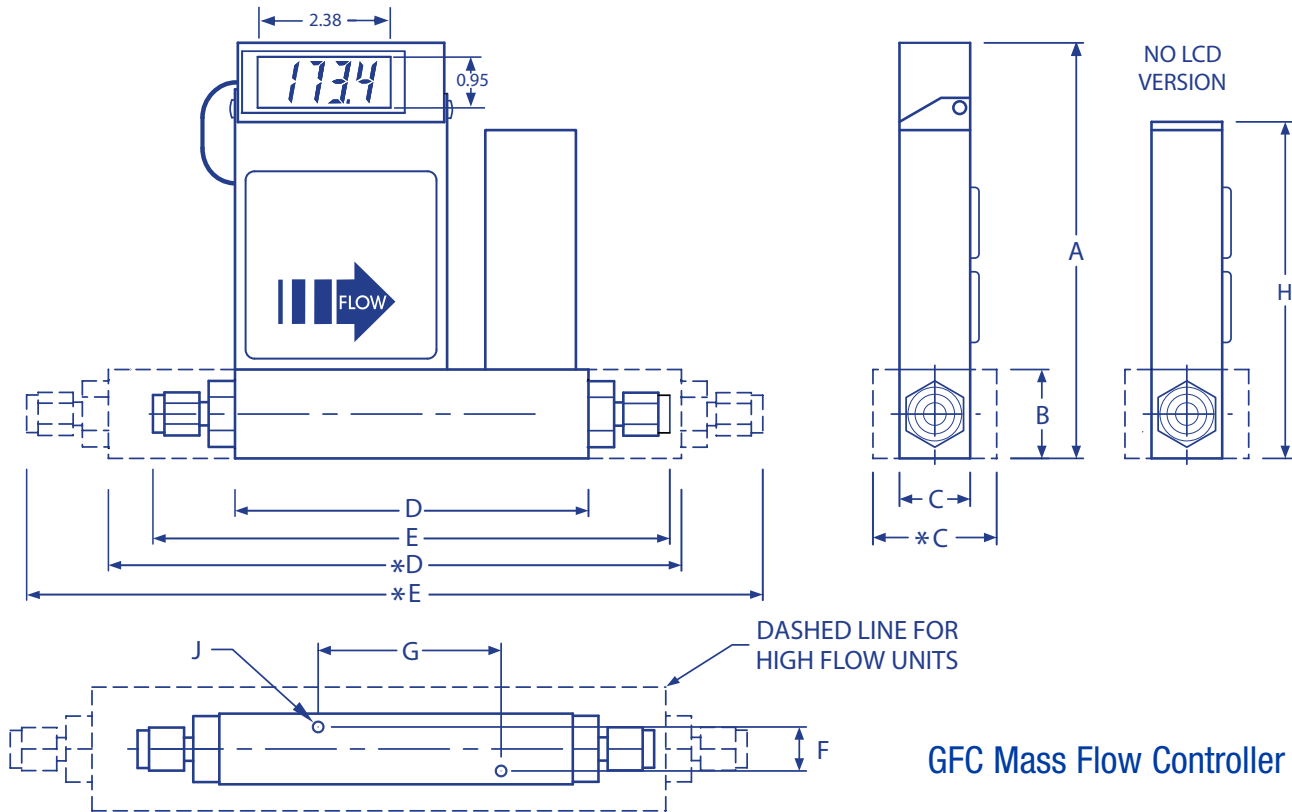

GFC Mass Flow Controller

TABLE 16 - DIMENSION FOR GFC

MODEL	CONNECTION COMPRESSION FITTING (except model GFC 77)	DIMENSION (INCH)								
		LCD VERSION							NO LCD	MOUNTING HOLE
		A	B	C/*C	D/*D	E/*E	F	G		
GFC 17	1/4" Tube O Diameter	5.60	1.00	1.00	4.27	6.29	0.69	2.69	4.50	6-32
GFC 37	1/4" Tube O Diameter	5.98	1.37	1.25	5.19	7.21	0.69	2.69	4.88	6-32
GFC 47	3/8" Tube O Diameter	5.98	1.37	1.25	5.19	7.33	0.69	2.69	4.88	6-32
GFC 57	3/8" Tube O Diameter	6.60	2.00	1.75	10.2	12.3	1.39	4.69	6.60	10-24
GFC 67	1/2" Tube O Diameter	7.56	3.00	3.00	10.24	12.4	2.5	6.80	7.56	1/4-20
GFC 77	3/4" NPT Female	8.56	4.00	4.00	10.5	—	3.0	6.80	8.56	1/4-20

GFC	MODEL	
	MAX. FLOW (N ₂)	
	17	10 L/min
	37	50 L/min
	47	100 L/min
	57	200 L/min
	67	500 L/min
	77	1000 L/min
	MATERIAL	
	A	Aluminum
	S	Stainless Steel
	SEALS	
	V	Viton®
	B	Buna®
	E	EPR
	T	PTFE/ Kalrez®
	FITTINGS	
	A	1/4" Compression
	B	1/8" Compression
	C	1/4" VCR®
	D	3/8" Compression
	E	1/2" Compression
	F	3/4" FNPT
	G	3/4" Compression
	H	6mm Compression
	MODEL	
	A	GFC 17, 37
	B	GFC 17
	C	GFC 17, 37
	D	GFC 17, 37, 47, 57
	E	GFC 67
	F	GFC 77
	G	GFC 77
	H	GFC 17, 37
	DISPLAY	
	N	No display
	L	LCD readout
	POWER	
	6	Universal +12 Vdc to 26 Vdc
	2	12 Vdc
	4	24 Vdc
	MODEL	
	6	GFC 17, 37 and 47
	2	GFC 57, 67 and 77
	4	GFC 57, 67 and 77
	INPUT/OUTPUT SIGNAL	
	A	Local 0-5 Vdc
	B	Local 4-20 mA
	C	0-5Vdc/0-5Vdc
	D	0-5Vdc/4-20mA
	E	4-20mA/4-20mA
	F	4-20mA/0-5Vdc
	DIGITAL INTERFACE	
	0	None

GFC 17 S - V A L 2 - C 0

EXAMPLE: GFC17S-VAL2-C0 10 L/min [N₂] 20 psig

SPECIFY: FLOW RANGE, GAS and PRESSURE

GFC17 stainless steel, Viton® seals, 1/4" compression fittings with display, 12Vdc, 0-5 Vdc. Out put signal, No digital interface

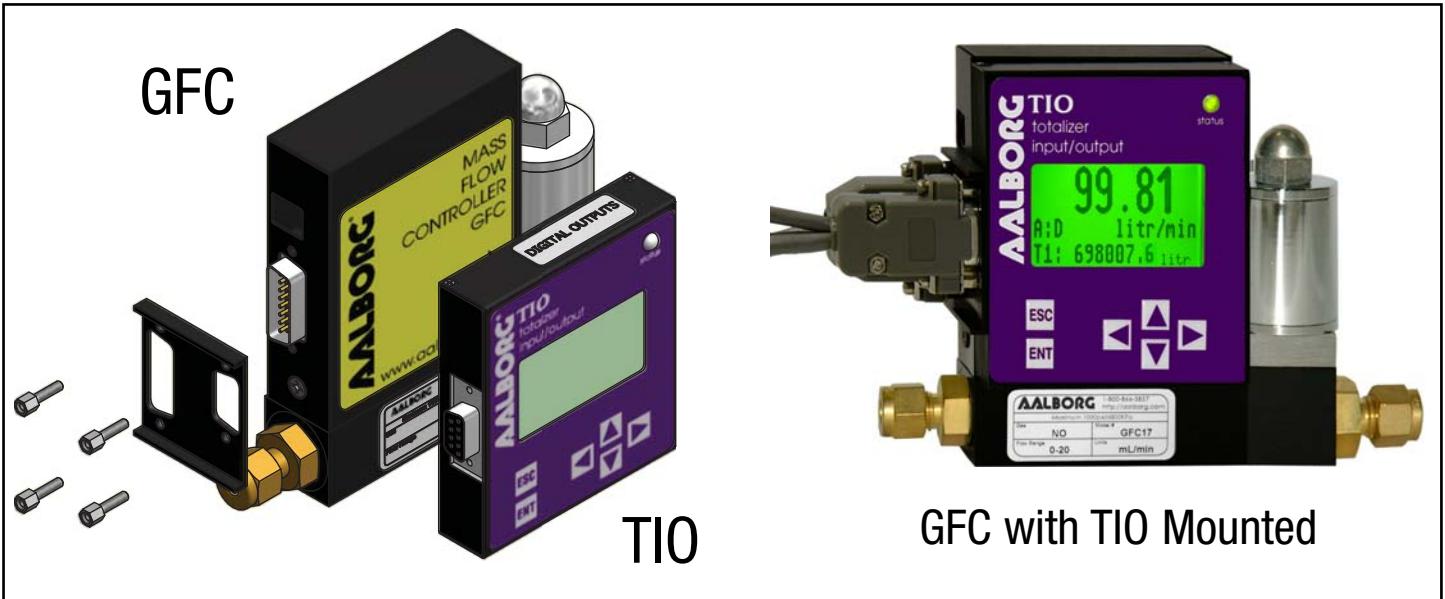
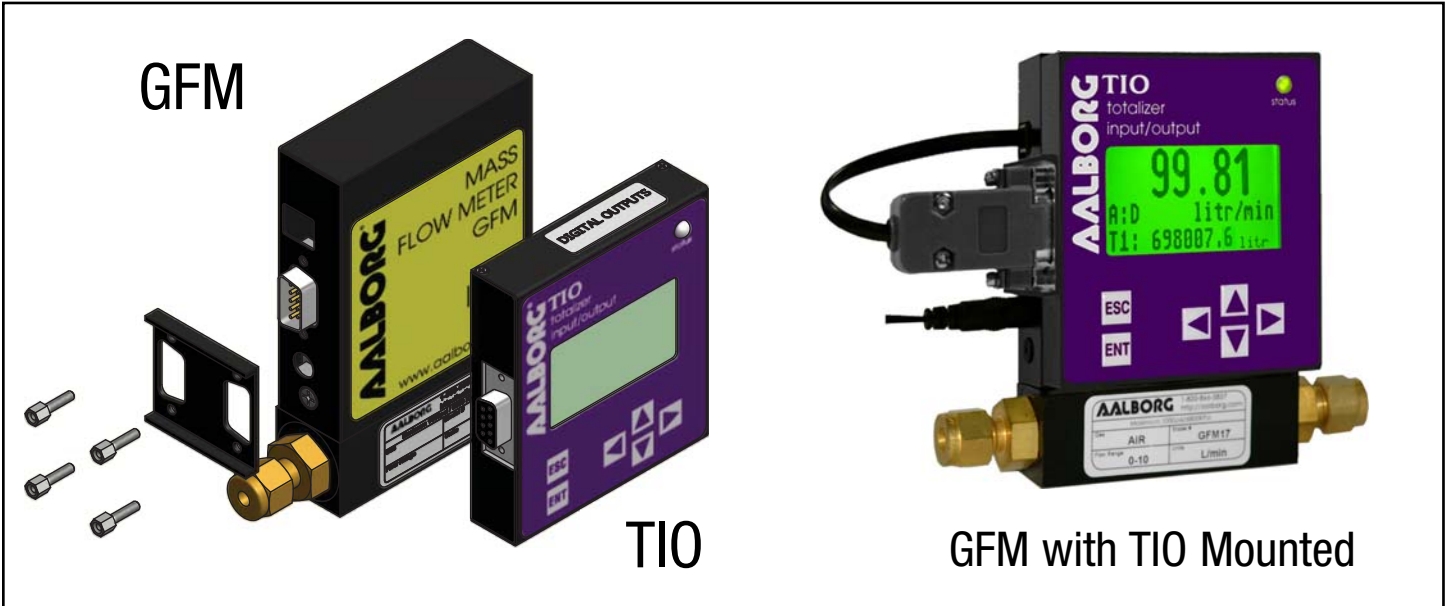

Design Features

- Displays instantaneous, total and accumulated flow rates.
- Built-in Flow Linearizer (10 point linearization of the flow curve).
- Up to 47 different volumetric and mass flow engineering units.
- Large 13mm (0.51") digits for flow rate and 5.5mm (0.21") for Total.
- Digital RS-232 or RS-485 interface (multi-drop capability of up to 64 devices.)
- Compact design for unit mount, panel mount, wall mount or field mount applications.
- User-programmable, optically-isolated pulse output.
- Two programmable, optically-isolated, digital outputs.
- Flow controllers, set point command control via local LCD or digital interface.
- Programmable set point table with ramping up/down capability up to 16 steps.
- Free Configuration and Monitoring Utility software.



Applications

For flow meters and controllers with analog 0-5 (5-10) (0-10)Vdc, 4-20mA input output interface, where flow indications / control and totalizers or alarm functions are required. Also when re-transmission of the flow rate and/or totalizer functions via optically-isolated pulse output or serial communication is desired. Local or programmable set point control for flow controllers (no host PC presence required). Activation of user-supplied equipment via programmable optically-isolated digital outputs when flow alarms or totalizers events are active.

Display

The graphical LCD display has large 13mm (0.51") digits for flow rate and 5.5mm (0.21") for total and can be set by user to simultaneously show different combination of the flow parameters: flow rate, totalizers, flow alarms, and diagnostic events . All configuration parameter settings are easily accessed via a simple user-interface menu driven by a 6 button key-pad which can be password-protected.

Signal Input and Signal Output

- 0-5 Vdc (Input/Output)
 - 5-10 Vdc (Output only)
 - 0-10 Vdc (Input/Output)
 - 4-20 mA (Input/Output)
- For flow meters and / or flow controllers, TIO provides jumpers selectable for 0-5 Vdc or 4-20 mA analog set point control signals. The flow rate set point can be adjusted locally via key-pad, remotely via host PC using digital communication interface, or programmed in advance using built-in 16 steps batch table with ramping up/down support.

Programmable Pulse Output

The programmable flow pulse output is operating independently from totalizers and based on configuration settings can provide pulse frequency proportional to instantaneous fluid flow rate.

The LCD/keypad and digital communication interface commands are provided to:

- Enable/Disable Pulse Output.
- Configure Pulse Output start flow rate (in % of full scale).
- Configure the Unit/Pulse value (in current volumetric or mass flow units).
- Configure Pulse Active On Time (10 - 6550 ms).

Programmable Totalizers

TIO provides two independent programmable flow totalizers. Both totalizers are updated every 100 ms and can be set to activate different events. Main totalizer accumulated total is backed-up in EEPROM memory every second.

The LCD/keypad and digital communication interface commands are provided to:

- Enable/Disable totalizing the flow.
- Start the totalizer at a preset flow rate (in % of full scale).
- Assign action at a preset total volume (Event Volume).
- Configure power on delay (in seconds).
- Configure Auto Reset at preset volume.
- Configure Auto Reset delay (in seconds).
- Reset the totalizer to ZERO.



Programmable Alarms

TIO provides the user with a flexible alarm/warning system that monitors the fluid flow for conditions that fall outside configurable limits as well as visual feedback for the user via the LCD or via an optically-isolated output. The flow alarm has several attributes which can be configured by the user via LCD/Keypad or digital communication interface:

- Enable/Disable flow alarm.
- Low flow alarm settings (in % of full scale).
- High flow alarm settings (in % of full scale).
- Flow alarm action delay.
- Flow alarm action latch mode.

Digital Communication

All process data and settings can be read and modified manually via local LCD Key-pad or through the digital RS-232 or RS-485 communication interface. Proprietary ASCII software interface command set and free Communication Utility software are provided.

TABLE 17 - SPECIFICATIONS

ADC/DAC RESOLUTION:	12 bit
ANALOG INPUTS	0-5 Vdc, 4-20 mA, 5-10 Vdc (jumper-selectable), 0-10 Vdc (special order)
ANALOG OUTPUTS:	0-5 Vdc, 4-20 mA (jumper-selectable)
LCD:	128x64 graphic LCD with instantaneous Flow reading and Total volume indication. Adjustable LCD contrast and back light.
KEY-PAD:	Local 6 tactical push buttons.
PULSE OUTPUT:	User-programmable, optically-isolated, with preset active low time interval (10 – 6550 ms).
DIGITAL OUTPUT:	Two programmable, optically-isolated, UCE @ 40Vdc, ICE @ 150 mA (Voltage Isolation: 250 Vrms).
DIGITAL INTERFACE:	RS-232 or RS-485 (multidrop capability up to 64 devices)
 PROTOCOL:	Proprietary ASCII software interface command set.
 SPEED:	1200 - 2400 - 4800 - 9600 -19200 – 38400 – 57600 – 115200 baud (user selectable).
 CONFIGURATION:	Stop bit: 1 Data bits: 8 Parity: None Flow Control: None
 ADDRESSING:	Maximum 255 addresses (for RS-485 option only).
 TYPE:	RS232 or RS485 2-wire.
POWER REQUIREMENTS:	12 – 26 Vdc (up to 60 mA maximum).
INTERFACE CONNECTORS:	Process I/O signals and Digital RS-232/RS-485 interface – miniature 9 pin female D-SUB connector. Digital optically-isolated outputs: TERM BLOCK HEADER 4POS 3.5MM Male Pins, Shrouded.
ENVIRONMENT:	Installation Level II, Pollution Degree II, (Per IEC 664).
ELECTROMAGNETIC COMPATIBILITY:	Compliant ref. 89/336/EEC as amended. Emission Standard: EN 55011:1991, Group 1, Class A Immunity Standard: EN 55082- 1:1992
OPERATING TEMPERATURE:	-10 °C to +70 °C (14°F to +158 °F).
DIMENSIONS:	86.4 x 76.2 x 19.1 mm (3.4" x 3.0" x 0.75") - W x H x D.
WEIGHT:	Appr. 125g / 0.3 lbs

BULLETIN EM201412 TIO



TABLE 18 - TIO ACCESSORY'S

PART NUMBER	DESCRIPTION	WHEN REQUIRED
KIT-TM-DD	GFM flow meter mounting kit, shielded cable with two 9 pins D-connectors for process signals and communication branch.	GFM + digital communication with Host PC or PLC.
KIT-TM-RD	GFM flow meter mounting kit, 4 wire cable between GFM RJ11 and TIO 9 pin D-connector.	GFM (12 Vdc power option only), 5-10 Vdc input, no digital communication.
KIT-TM-FD	GFM flow meter mounting kit, flat wire cable between GFM and TIO 9 pin D-connectors.	GFM, 0-5Vdc input no digital communication.
KIT-TC-110NA-2C	GFC flow controller mounting kit, shielded cable with North America plug 110 Vac to 12 Vdc power supply, communication branch.	GFC, 0-5 Vdc input, North America 12 Vdc power supply, digital communication.
KIT-TC-110NA-2N	GFC flow controller mounting kit, shielded cable with North America plug 110 Vac to 12 Vdc power supply.	GFC, 0-5 Vdc input, North America 12 Vdc power supply.
KIT-TC-110NA-4C	GFC flow controller mounting kit, shielded cable with North America plug 110 Vac to 24 Vdc power supply, communication branch.	GFC, 0-5 Vdc input, North America 12 Vdc power supply.
KIT-TC-110NA-4N	GFC flow controller mounting kit, shielded cable with North America plug 110 Vac to 24 Vdc power supply.	GFC, 0-5 Vdc input, North America 24 Vdc power supply.
KIT-TC-230EU-2C	GFC flow controller mounting kit, shielded cable with EUROPE plug 230 Vac to 12 Vdc power supply, communication branch.	GFC, 0-5 Vdc input, Europe 12 Vdc power supply, digital communication.
KIT-TC-230EU -2N	GFC flow controller mounting kit, shielded cable with EUROPE plug 230 Vac to 12 Vdc power supply.	GFC, 0-5 Vdc input, Europe 12 Vdc power supply.
KIT-TC-230EU -4C	GFC flow controller mounting kit, shielded cable with EUROPE plug 230 Vac to 24 Vdc power supply, communication branch.	GFC, 0-5 Vdc input, Europe 24 Vdc power supply, digital communication.
KIT-TC-230EU -4N	GFC flow controller mounting kit, shielded cable with EUROPE plug 230 Vac to 24 Vdc power supply.	GFC, 0-5 Vdc input, Europe 24 Vdc power supply.
KIT-TC-240AU-2C	GFC flow controller mounting kit, shielded cable with AUSTRALIA plug 240 Vac to 12 Vdc power supply, communication branch.	GFC, 0-5 Vdc input, Australia 12 Vdc power supply, digital communication.
KIT-TC-240AU-2N	GFC flow controller mounting kit, shielded cable with AUSTRALIA plug 240 Vac to 12 Vdc power supply.	GFC, 0-5 Vdc input, Australia 12 Vdc power supply.
KIT-TC-240AU-4C	GFC flow controller mounting kit, shielded cable with AUSTRALIA plug 240 Vac to 24 Vdc power supply, communication branch.	GFC, 0-5 Vdc input, Australia 24 Vdc power supply, digital communication.
KIT-TC-240AU-4N	GFC flow controller mounting kit, shielded cable with AUSTRALIA plug 240 Vac to 12 Vdc power supply.	GFC, 0-5 Vdc input, Australia 24 Vdc power supply.
KIT-TC-240UK-2C	GFC flow controller mounting kit, shielded cable with UK plug 240 Vac to 12 Vdc power supply, communication branch.	GFC, 0-5 Vdc input, UK 12 Vdc power supply, digital communication.
KIT-TC-240UK -2N	GFC flow controller mounting kit, shielded cable with UK plug 240 Vac to 12 Vdc power supply.	GFC, 0-5 Vdc input, UK 12 Vdc power supply.
KIT-TC-240UK -4C	GFC flow controller mounting kit, shielded cable with UK plug 240 Vac to 24 Vdc power supply, communication branch.	GFC, 0-5 Vdc input, UK 24 Vdc power supply, digital communication.
KIT-TC-240UK-4N	GFC flow controller mounting kit, shielded cable with UK plug 240 Vac to 24 Vdc power supply.	GFC, 0-5 Vdc input, UK 24 Vdc power supply.
KIT-TC-240UK-2AC	GFC flow controller mounting kit, shielded cable with UK plug 240 Vac to 12 Vdc power supply, communication branch, analog 4-20 mA output branch from GFC.	GFC, 0-5 Vdc input, UK 12 Vdc power supply, digital communication, analog 4-20 mA output branch from GFC.
KIT-TC-240UK-4AC	GFC flow controller mounting kit, shielded cable with UK plug 240 Vac to 24 Vdc power supply, communication branch, analog 4-20 mA output branch from GFC.	GFC, 0-5 Vdc input, UK 24 Vdc power supply, digital communication, analog 4-20 mA output branch from GFC.
KIT-TM	GFM flow meter mounting kit, no cables.	GFM, user-supplied custom cables.
KIT-TC	GFC flow controller mounting kit, no cables.	GFC, user-supplied custom cables.
CBL-DA9-X	9 conductor round shielded cable consisting of a 9 pin Female "D" Sub-Connector (plug) on one end, and loose wires on the other end.	For TIO stand alone option, user-supplied power supply.

Note: X – represent the length of the cable in feet



TIO	MODEL										
<table border="1"> <tr> <th colspan="2">DISPLAY / KEYPAD</th> </tr> <tr> <td>N</td> <td>No Display / No Key Pad</td> </tr> <tr> <td>L</td> <td>LCD / Key Pad</td> </tr> </table>		DISPLAY / KEYPAD		N	No Display / No Key Pad	L	LCD / Key Pad				
DISPLAY / KEYPAD											
N	No Display / No Key Pad										
L	LCD / Key Pad										
<table border="1"> <tr> <th colspan="2">INPUT SIGNAL</th> </tr> <tr> <td>A</td> <td>0-5 VDC</td> </tr> <tr> <td>B</td> <td>4-20 mA</td> </tr> <tr> <td>C</td> <td>0-10 VDC</td> </tr> <tr> <td>D</td> <td>5-10 VDC</td> </tr> </table>		INPUT SIGNAL		A	0-5 VDC	B	4-20 mA	C	0-10 VDC	D	5-10 VDC
INPUT SIGNAL											
A	0-5 VDC										
B	4-20 mA										
C	0-10 VDC										
D	5-10 VDC										
<table border="1"> <tr> <th colspan="2">OUTPUT SIGNAL</th> </tr> <tr> <td>A</td> <td>0-5 VDC</td> </tr> <tr> <td>B</td> <td>4-20 mA</td> </tr> <tr> <td>C</td> <td>0-10 VDC</td> </tr> </table>		OUTPUT SIGNAL		A	0-5 VDC	B	4-20 mA	C	0-10 VDC		
OUTPUT SIGNAL											
A	0-5 VDC										
B	4-20 mA										
C	0-10 VDC										
<table border="1"> <tr> <th colspan="2">DIGITAL INTERFACE</th> </tr> <tr> <td>2</td> <td>RS-232</td> </tr> <tr> <td>5</td> <td>RS-485</td> </tr> </table>		DIGITAL INTERFACE		2	RS-232	5	RS-485				
DIGITAL INTERFACE											
2	RS-232										
5	RS-485										
TIO	— L A A 2										

EXAMPLE: TIO-LAA2

Totalizer I/O Flow Monitor / Controller with LCD Key Pad, 0-5 VDC Input, 0-5 VDC Output and RS-232 Digital Interface.



Programmable Mass Flow Controller with Digital Signal Processing

Microprocessor driven **digital** flow controllers allow one to program, record, and analyze flow rates of various gases with a computer via an RS-485 interface. Optional RS-232 is available.

Controllers can be programmed for various control functions including flow set point, totalizer, stop totalizer, read totalizer, totalizer from preset flow, stop at preset total, auto zero, and more.



Design Features

- Digital and Analog modes operate simultaneously.
- Programmable Flow Configurations.
- Multi-Drop Capability of up to 256 units.
- Stores calibration data for up to 10 gases.
- Auto Tune function for optimum control response.
- Free PC Software with Gas Blending and Programmable Flow functions.
- Totalizer indicates total gas quantity.
- Alarm limits for high and low gas flow.
- Conversion factors for up to 256 gases.
- Self-Diagnostic Tests.

Principles of Operation

Metered gases are divided into two laminar flow paths, one through the primary flow conduit, and the other through a capillary sensor tube. Both flow conduits are designed to ensure laminar flows and therefore the ratio of their flow rates is constant.

Two precision temperature sensing windings on the sensor tube are heated, and when flow takes place, gas carries heat from the upstream to the downstream windings. The resultant temperature differential is proportional to the change in resistance of the sensor windings.

A Wheatstone bridge design is used to monitor the temperature dependent resistance gradient on the sensor windings which is linearly proportional to the instantaneous rate of flow. The output of the Wheatstone bridge is converted to digital format with a 12 Bit ADC (analog to digital converter).

An on-board microprocessor and non-volatile memory store all calibration factors and directly control a proportionating electromagnetic valve. The digital closed loop control system continuously compares the mass flow output with the selected flow rate.

Deviations from the set point are corrected by compensating valve adjustments, with PID algorithm thus maintaining the desired flow parameters with a high degree of accuracy. Output signals of 0 to 10Vdc, 0 to 5Vdc or 4 to 20mA are generated indicating mass molecular based flow rates of the metered gas.

Interface

The digital RS-485 (optional RS-232) interface provides access to applicable internal data including **FLOW SET POINT, ACTUAL FLOW, ZERO ADJUSTMENTS, and LINEARIZATION TABLE ADJUSTMENTS.**

The analog interface provides 0 to 5Vdc, 0 to 10Vdc and 4 to 20 mA inputs and outputs.

Auto Zero

The DFC automatically nulls the sensor zero offset whenever the flow set point is below 2% of full scale. To accommodate this feature the control valve must fully close under that condition. Provisions are made to either disable, force or store the current auto zero via digital commands.

Totalizer

The firmware for the DFC provides functions to register total gas quantity. The total mass of gas is calculated by integrating the actual gas flow rate with respect to time.

Digital interface commands are provided to:

- Set the totalizer to zero.
- Start /stop totalizing the flow.
- Read the totalizer.
- Start the totalizer at a preset flow.
- Stop the flow at a preset total.

Multi-Gas Calibration

The DFC is capable of storing primary calibration data for up to 10 gases. This feature allows the same DFC to be calibrated for multiple gases while maintaining the rated accuracy on each.

Conversion Factors

Conversion factors for up to 256 gases are stored in the DFC. Conversion factors may be applied to any of the ten gas calibrations via digital interface commands.

Flow Alarms

High and Low gas flow ALARM limits are programmed using the digital interface. Alarm conditions are reported via the digital interface or can activate the contact closure outputs.

Gas Blending Feature

Aalborg free software allows controlling flow of the Gas mixture of up to eight different gases (for RS-485 bus with 8 DFC controllers) with preset values of the ratio in % for each channel. The flow rate of the Gas Mixture can be incremented or decremented within allowable range (based on Full Scale range of all DFC controllers in the mixture system) by changing the Gas Mixture set point settings. The software will automatically adjust individual set point for each device according to set ratios.

Programmable Flow

Aalborg software supports programmable flow modes, allowing execution of custom programming of up to ten steps. Various flow configurations include ramping, linearized increasing and decreasing modes.

Auto Tune

The AUTO TUNE function allows the DFC to automatically optimize control response for the gas under actual process conditions. During the AUTO TUNE process, the instrument adjusts PID gains for optimum step response and determine key control valve characteristics (only available on units with less than 80 L/min maximum flow).

Contact Closure

Two sets of dry contact relay outputs are provided to actuate user supplied equipment. These are programmable via the digital interface such that the relays can be made to switch when a specified event occurs (e.g. when a low or high flow alarm limit is exceeded or when the totalizer reaches a specified value).

Valve Override

Means are provided to force the control valve fully open (purge) or fully closed via either the analog or digital interfaces.

Self-Diagnostics

Whenever power is first applied, the DFC runs a series of SELF-DIAGNOSTIC TESTS to ensure that it is in optimum working condition.

Engineering Units

The flow set point, measured gas flow and associated totalizer data is scaled directly in engineering units via digital interface commands. The following units of measure are supported: % of FS, mL/min, mL/hr, scfm, scfh, L/min, L/hr, lbs/hr, lbs/min, and one user defined unit of measure.

Leak Integrity

1×10^{-9} smL/sec of Helium maximum to the outside environment.

Balanced Power Supply

The DFC operates on ± 15 Vdc. The current requirements for the positive and negative power supplies are balanced such that the current in the power supply common connection is minimized. Maximum power consumption is 13.5 watts at ± 15 Vdc.

TABLE 19 - SPECIFICATIONS

ACCURACY:	±1% of FS at calibration temperature and pressure.
CALIBRATIONS:	Performed at standard conditions [14.7 psia (101.4 kPa) and 70 °F (21.1 °C)] unless otherwise requested.
REPEATABILITY:	±0.15% of full scale.
RESPONSE TIME:	1.0 to 2.0 second to within ±2% of set point over 20% to 100% of full scale.
TEMPERATURE COEFFICIENT:	0.05% of full scale/ °F or better.
PRESSURE COEFFICIENT:	0.01% of full scale /psi (0.07 bar) or better.
OPTIMUM GAS PRESSURE:	25 psig (1.73 bars).
MAXIMUM GAS PRESSURE:	1000 psig (70 bars).
MAXIMUM DIFFERENTIAL PRESSURE:	50 psig (3.4 bars) for DFC 26 and DFC 36 40 psig (2.8 bars) for DFC 46
MAX PRESSURE DROP:	Refer to Table 23.
GAS and AMBIENT TEMP:	32 °F to 122 °F (0 °C to 50 °C). 14 °F to 122 °F (-10 °C to 50 °C) - Dry gases only.
COMMUNICATION INTERFACE:	RS485 - Standard. RS232 - Optional.
OUTPUT SIGNALS:	Linear 0-5 Vdc (2000 ohms min load impedance); impedance); 0-10Vdc (4000 ohms min impedance); 4-20 mA optional (0-500 ohms\ loop resistance). Maximum noise 20mV peak to peak.
CIRCUIT PROTECTION:	Circuit boards have built-in polarity reversal protection. Resettable fuses provide power input protection.
**MATERIALS IN FLUID CONTACT:	316 stainless steel, 416 stainless steel, Viton® O-rings. Optional O-rings: Buna®, EPR and Kalrez®.
ATTITUDE SENSITIVITY:	No greater than +15 degree rotation from horizontal to vertical; standard calibration is in horizontal position.
CONNECTIONS:	<p>Model DFC 26/36: Standard 1/4" compression fittings. Optional: 6mm compression fittings or 3/8" compression fittings or 1/4" VCR® or 1/8" compression fittings (DFC 26).</p> <p>Model DFC 46: standard 3/8" compression fittings.</p>
LEAK INTEGRITY:	1 x 10 ⁻⁹ sml/sec of helium maximum to the outside environment.
TRANSDUCER INPUT POWER:	±15Vdc, 450 mA maximum.
CALIBRATION OPTIONS:	Standard 10 point NIST traceable calibration. Optional up to 9 additional 10 point calibrations may be ordered for an additional charge.
CE COMPLIANCE:	EN 55011 class 1, class B; EN50082-1.

***The selection of materials of construction, is the responsibility of the customer. The company accepts no liability.*

DFC 26 Mass Flow Controller

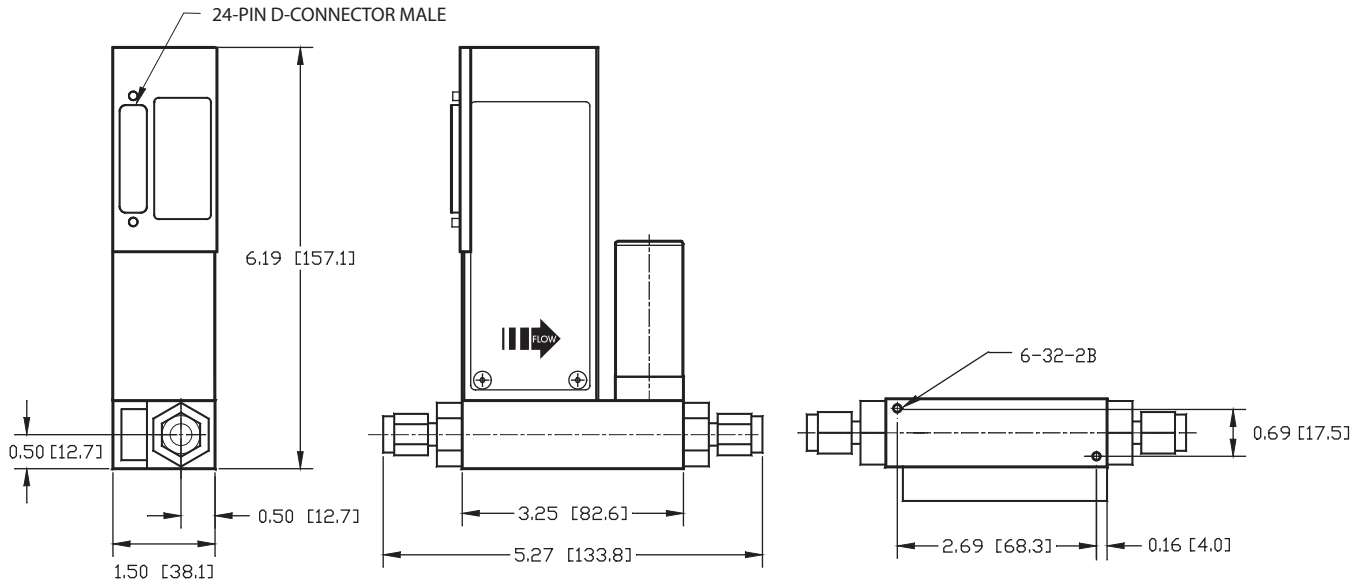

DFC 36/46 Mass Flow Controller

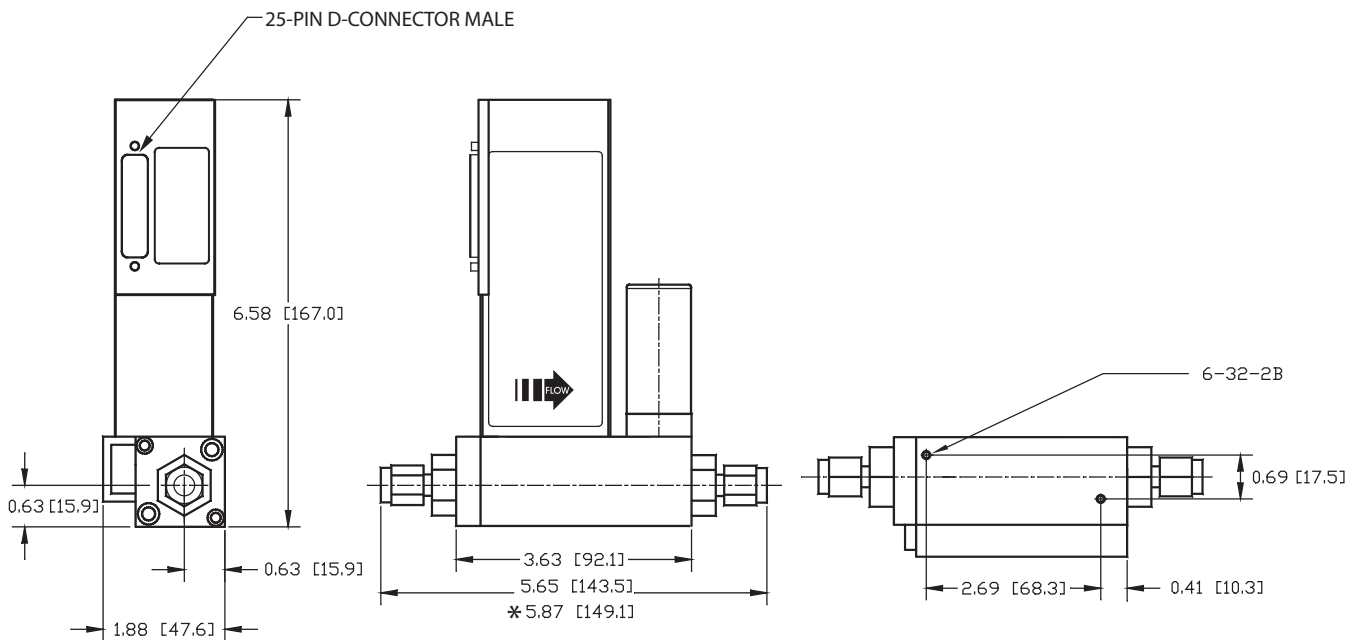

* FOR HIGH FLOW MASS FLOW CONTROLLERS

TABLE 20 - FLOW RANGES FOR DFC

DFC 26 LOW FLOW CONTROLLERS		DFC 36 MEDIUM FLOW CONTROLLERS		DFC 46 HIGH MASS FLOW CONTROLLERS	
CODE	Units [Nitrogen]	CODE	L/min [N ₂]	CODE	L/min [N ₂]
01	0 to 10 mL/min	11	0 to 15 L/min	40	0 to 60 L/min
02	0 to 20 mL/min	30	0 to 20 L/min	41	0 to 80 L/min
03	0 to 50 mL/min	31	0 to 30 L/min	42	0 to 100 L/min
04	0 to 100 mL/min	32	0 to 40 L/min		
05	0 to 200 mL/min	33	0 to 50 L/min		
06	0 to 500 mL/min				
07	0 to 1 L/min				
08	0 to 2 L/min				
09	0 to 5 L/min				
10	0 to 10 L/min				

TABLE 21 - ACCESSORIES AND READOUTS FOR DFC

CBL-DFC	25 pin D-connector with 6 ft. wire to computer port stripped, Branch 6ft. wire to customers power supply.
CBL-DFC-DPM-AIO	Cable stripped for DFC with LCD jack and analog input/output.
CBLDFC-PROC	25 pin D-connector with 6ft. wire to 15 pin DM, Branch 6ft. wire to computer port stripped.
PS-DFC-110NA-5-S	Power supply with 25 pin female D-connector 110/vac (±15Vdc.) Branch 6ft wire to computer port stripped /North America.
PS-DFC-110NA-5-A	Power supply with 25 pin D-connector, analog interface 110/vac (+ - 15Vdc.) (North America).
PS-DFC-230EU-5-S	Power supply with 25 pin female D-connector 230/vac (±15Vdc.) Branch 6ft wire to computer port stripped /Europe.
PS-DFC-240UK-5-S	Power supply with 25 pin female D-connector 240/vac (±15Vdc.) Branch 6ft wire to computer port stripped /United Kingdom.
PS-DFC-240AU-5-S	Power supply with 25 pin female D-connector 240/vac (±15Vdc.) Branch 6ft wire to computer port stripped /Australia.
BCKUPDFC	Digital panel meter / led backlight.
PS-DFC-110NA-5-S-D	Power supply DFC 110/Vac ±15Vdc standard interface and LCD jack. (United States).
PS-DFC-110NA-5-A-D	Power supply DFC 110/Vac ±15Vdc analog interface and LCD jack. (United States).

TABLE 22 - MAXIMUM PRESSURE DROP FOR DFC

MODEL NO.	MAX. FLOW (N ₂)	MAXIMUM PRESSURE DROP		
		[mm H ₂ O]	[psid]	[mbar]
DFC 26	up to 10	720	1.06	75
	15	2630	3.87	266
DFC 36	20	1360	2.00	138
	30	2380	3.50	241
	40	3740	5.50	379
	50	5440	8.00	551
	60	7480	11.00	758
DFC 46	100	12850	18.89	1302

Cable Options

Standard Cable (supplied with Transducer) CBL-DFC

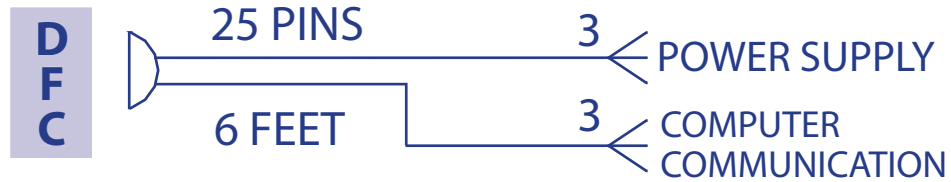

CBL-DFC-SDPROC

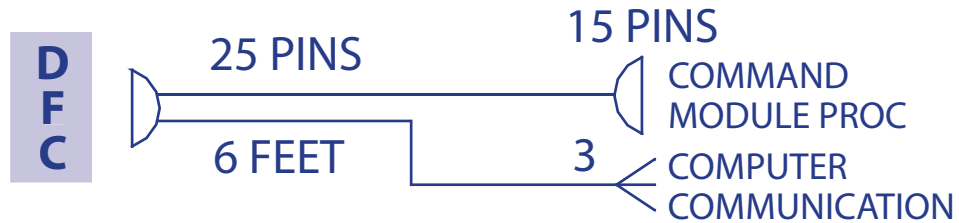

PS-DFC-110NA-5-S 230EU /240UK /240AU

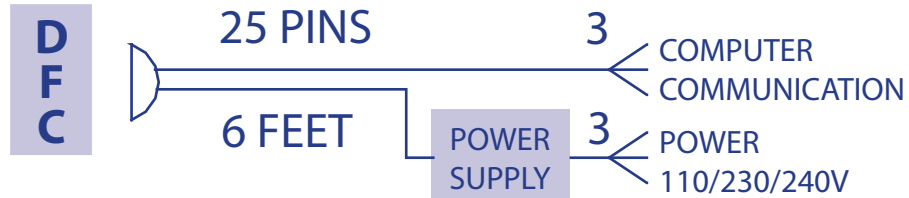

PS-DFC-110NA-5-A
230EU /240UK /240AU

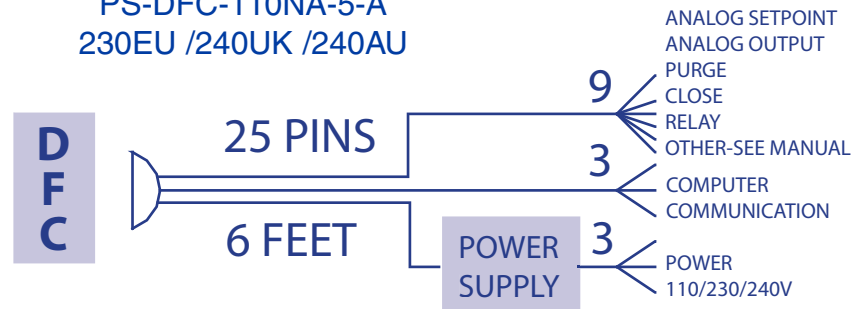



DFC	MODEL
MAX. FLOW (N ₂)	
26	10 L/min
36	50 L/min
46	100 L/min
MATERIAL	
S	Stainless Steel

SEALS	
V	Viton®
B	Buna®
E	EPR
T	PTFE / Kalrez®

FITTINGS		MODEL
A	1/4" Compression	DFC 26, 36
B	1/8" Compression	DFC 26
C	1/4" VCR®	DFC 26, 36
D	3/8" Compression	DFC 26, 36, 46
H	6mm Compression	DFC 26, 36

DISPLAY	
N	No Display
L	LCD Readout (Special interface cable is required).

POWER	
5	±15 Vdc

INPUT / OUTPUT SIGNAL	
C	0-5Vdc/ 0-5Vdc
D	0-5Vdc/ 4-20mA
E	4-20mA/ 4-20mA
F	4-20mA/ 0-5Vdc
H	0-5 Vdc/ 0-10Vdc
I	0-10Vdc/ 0-5 Vdc
J	0-10Vdc/ 0-10 Vdc
K	4-20 mA/ 0-10 Vdc
L	0-10 Vdc/ 4-20 mA

DIGITAL INTERFACE	
2	RS232
5	RS485

DFC 36 S — V A N 5 — C 5

EXAMPLE: DFC36S-VAN5-C5 50 L/min [N₂] 20 psig
SPECIFY: FLOW RANGE, GAS and PRESSURE.

DFC 36 stainless steel, Viton® seals, 1/4" compression fittings, No display, ±15 Vdc power, 0-5 Vdc/0-5 Vdc input output signal, RS485 digital interface.

BULLETIN EM201412 DFC

Multi Parameter flow meters provide accurate data on three different fluid parameters:

- **flow**
- **pressure**
- **temperature**

The flow rate can be displayed in volumetric flow or mass flow engineering units for standard or actual (temperature, pressure) conditions. Flow meters can be programmed locally by the four button keypad and LCD or remotely via RS-232/RS-485 interface.

DFM flow meters support various functions including: flow totalizer, flow, temperature, pressure alarms, automatic zero adjustment, 2 relay outputs, 0-5 Vdc / 0-10 Vdc / 4-20 mA analog outputs for flow, pressure and temperature.

DFM's are offered either as Digital Mass Flow Meters, Model Numbers: DFM26, 36, & 46 or as a Digital Multi-Parameter Meters, Model Numbers, DFM27, 37 & 47. Model Numbers are displayed in Table 26.

THERE ARE 3 VOLTAGE (POWER) OPTIONS:
±15Vdc, 12Vdc, & 24Vdc.

Interface

All features of the flow meter can be accessed via the local four button keypad and LCD. The digital interface operates via RS485 (optional RS-232 is available) and provides access to applicable internal data including: flow, temperature, pressure reading, auto zero, totalizer and alarms settings, gas table, conversion factors and engineering units selection, dynamic response compensation and linearization table adjustment. The analog interface provides 0 to 5Vdc or 0 to 10Vdc or 4 to 20 mA outputs for flow, pressure and temperature (jumper selectable).

Auto Zero

The DFM supports automatic sensor zero offset adjustment which can be activated locally via the keypad or remotely via digital interface. The auto zero feature requires absolutely no flow through the meter during auto zero process. Provisions are made to either start, read, or save the current auto zero value via digital commands.



Totalizer

The total volume of the gas is calculated by integrating the actual gas flow rate with respect to time. Both keypad menu and digital interface commands are provided to:

- set the totalizer to ZERO.
- start the totalizer at a preset flow.
- assign action at a preset total volume.
- start/stop totalizing the flow.
- read totalizer.

Totalizer conditions become true, when the totalizer reading and the "Stop at Total" volumes are equal.

Flow Alarm

High and Low gas flow ALARM limits can be preprogrammed via keypad or remotely via digital interface. ALARM conditions become true when the current flow reading is equal or higher/lower than corresponding values of high and low alarm levels. Alarm action can be assigned with preset delay interval (0-3600 seconds) to activate the contact closer (separate for High and Low alarm).



Pressure Alarm

High and Low gas pressure ALARM limits can be preprogrammed via the keypad or remotely via digital interface. Pressure alarm conditions become true when the current pressure reading is equal or higher than corresponding values of high pressure alarm settings or equal or lower than corresponding values of low pressure alarm settings. Alarm action can be assigned to activate the contact closer (separate for High and Low pressure alarm).

Temperature Alarm

High and Low gas temperature ALARM limits can be preprogrammed via the keypad or remotely via digital interface. Temperature alarm conditions become true when the current temperature reading is equal or higher than corresponding values of high temperature alarm settings or equal or lower than corresponding values of low temperature alarm settings. Alarm action can be assigned to activate the contact closer (separate for High and Low temperature alarm).

TABLE 23 -SPECIFICATIONS

ACCURACY:	±1% of FS at calibration temperature and pressure.
CALIBRATIONS:	Performed at standard conditions [14.7 psia (101.4 kPa) and 70 °F (21.1°C)] unless otherwise stated.
PRESSURE RANGE (MEASUREMENT):	5 to 100 psia (0.34 to 6.8 bars).
PRESSURE ACCURACY:	±1% of FS.
TEMPERATURE RANGE (MEASUREMENT):	32 °F to 122 °F (0 °C to 50 °C).
TEMPERATURE ACCURACY:	±1 °C.
REPEATABILITY:	±0.25% of full scale.
RESPONSE TIME:	0.6 to 1.0 second to within ±2% of set flow over 20% to 100% of full scale.
TEMPERATURE COEFFICIENT:	0.15% / °C or better.
PRESSURE COEFFICIENT:	0.01% of full scale/ 1 psi (0.07 bar) or better.
OPTIMUM GAS PRESSURE:	25 psig (1.73 bars).
MAXIMUM GAS PRESSURE:	DFM 26/36/46: 1000 psig (68 barg, 6895 kPag). DFM 27/37/47: 100 psia (6.8 barabs, 689 kPaabs).
MAXIMUM BURST PRESSURE:	DFM 26/36/46: 1000 psig (68 barg, 6895 kPag). DFM 27/37/47: 200 psig (13.6 barg, 1379 kPag).
MAXIMUM PRESSURE DROP:	See table 25.
GAS and AMBIENT TEMP:	32 °F to 122 °F (0 °C to 50 °C). 14 °F to 122 °F (-10 °C to 50 °C) - Dry gases only.
OUTPUT SIGNALS:	Linear 0-5 Vdc (3000 ohms min load impedance); 0-10Vdc (6000 ohms min impedance); 4-20 mA optional (500 ohms max loop resistance). Maximum noise 20mV peak to peak.
INPUT POWER:	May be configured for three different options: ±15Vdc (±200 mA maximum); +12Vdc (300 mA maximum); +24Vdc (250 mA maximum); Circuit boards have built-in polarity reversal protection. Resettable fuses provide power input protection.
**MATERIALS IN FLUID CONTACT:	316 stainless steel, Viton® O-rings. Optional O-rings: Buna®, EPR and Kalrez®.
CONNECTIONS:	Model DFM26/27: Standard 1/4" compression fittings. Optional: 6mm compression fittings, 3/8" or 1/8" compression fittings and 1/4" VCR® fittings. Model DFM36/37: Standard 1/4" compression fittings. Optional: 6mm compression fittings, 3/8" compression fittings and 1/4" VCR® fittings. Model DFM46/47: Standard 3/8" compression fittings.
DISPLAY:	128 x 64 graphic LCD with backlight (up to 8 lines of text).
CALIBRATION OPTIONS:	Standard one 10 points NIST traceable calibration. Optional up to 9 additional calibrations may be ordered for an additional charge.
CE COMPLIANCE:	EN 55011 class 1, class B; EN50082-1.
ENVIRONMENTAL (PER IEC 664):	Installation Level II; Pollution Degree II.

***The selection of materials of construction, is the responsibility of the customer. The company accepts no liability.*



Engineering Units

The measured gas flow and associated totalizer data are scaled directly in engineering units via the front panel keypad or digital interface.

THE FOLLOWING UNITS OF MEASURE ARE SUPPORTED:

%F.S., L/min, L/h, mL/min, mL/h, scuft/h, scuft/min, lb/h, lb/min, one user defined engineering unit.

Multi-Gas Calibration

The DFM is capable of storing primary calibration data for up to 10 gases. This feature allows the same DFM to be calibrated for multiple gases while maintaining the rated accuracy on each.

Conversion Factors

Conversion factors for up to 32 gases are stored in the DFM. In addition provision is made for a user defined conversion factor. Conversion factors may be applied to any of the ten gas calibrations via keypad or digital interface commands.

Contact Closure

Two sets of dry contact relay outputs are provided to actuate user supplied equipment. These are programmable via the local keypad or digital interface such that the relays can be made to switch when a specified event occurs (e.g. when a low or high flow, pressure or temperature alarm limit is exceeded or when the totalizer reaches a specified value).

Leak Integrity

1 x 10⁻⁹ smL/sec of Helium maximum to the outside environment.

TABLE 24 - FLOW RANGES FOR DFM

DFM 26 / 27 LOW FLOW MASS METERS	
CODE	mL/min [N ₂]
01	0 to 10
02	0 to 20
03	0 to 50
04	0 to 100
05	0 to 200
06	0 to 500
CODE	L/min [N ₂]
07	0 to 1
08	0 to 2
09	0 to 5
10	0 to 10
DFM 36 / 37 MEDIUM FLOW MASS FLOW METERS	
CODE	L/min [N ₂]
11	0 to 15
30	20
31	30
32	40
33	50
DFM 46 / 47 HIGH FLOW MASS FLOW METERS	
CODE	L/min [N ₂]
40	60
41	80
42	100

TABLE 25 - PRESSURE DROP FOR DFM

MODEL	FLOW RATE [liters/min]	MAXIMUM PRESSURE DROP FOR DFM		
		[mm H ₂ O]	[psid]	[kPa]
DFM 26 /27	up to 10	25	0.04	0.276
	20	300	0.44	3.03
DFM 36 /37	30	800	1.18	8.14
	40	1480	2.18	15.03
	50	2200	3.23	22.3
DFM 46 /47	60	3100	4.56	31.4
	100	5500	8.08	55.7

Multi Parameter Mass Flow Meter with Digital Signal Processing

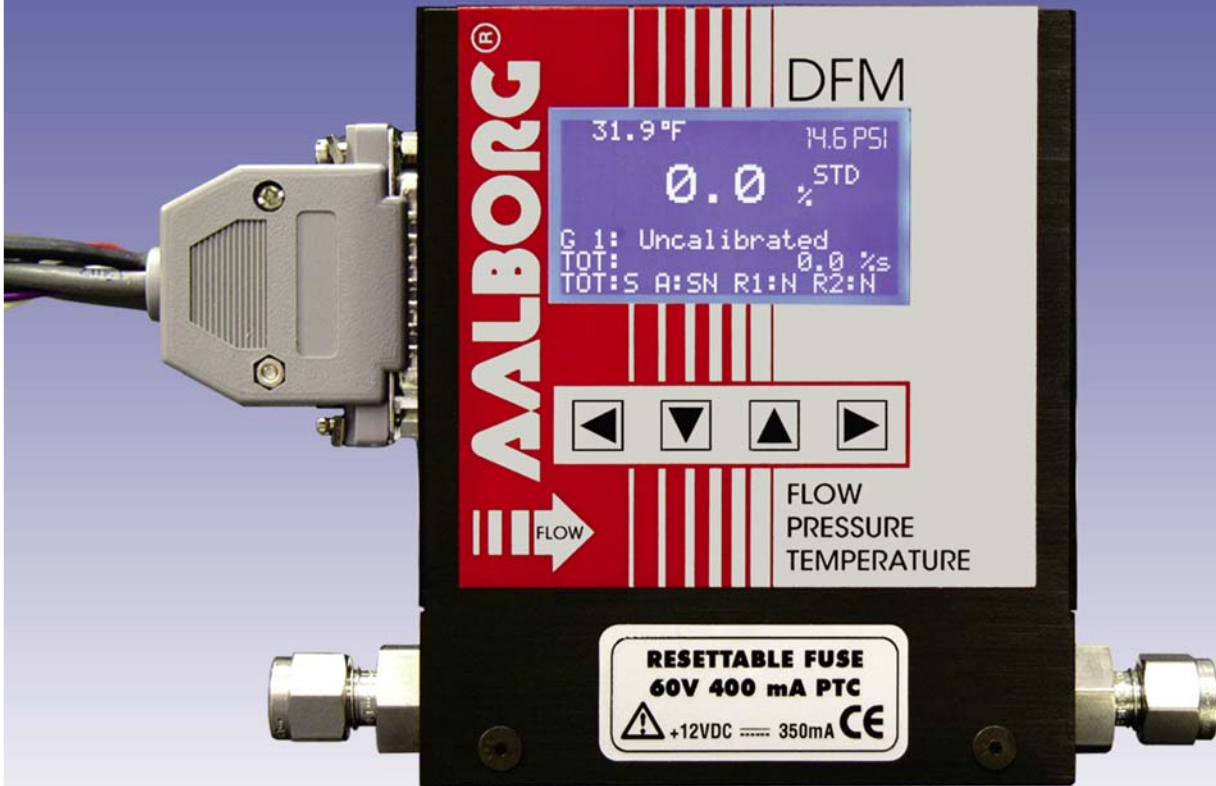

Design Features

- Multi-Drop Capability of up to 255 units (for RS-485 option).
- Stores calibration data for up to 10 different gases.
- Supports 10 different engineering units including user defined.
- Programmable 12 digits Totalizer indicates total gas volume.
- Flow Alarm limits for high and low gas flow with relay output.
- Pressure Alarm limits for high and low gas pressure with relay output.
- Temperature Alarm limits for high & low gas temp. with relay output.
- Four button keypad and large 128x64 graphical LCD with back light.
- Digital (RS-232 or RS-485) and Analog outputs operate simultaneously.
- Internal Conversion factors for up to 32 gases.
- Automatic Zero Adjustment.
- Self-Diagnostic Tests.

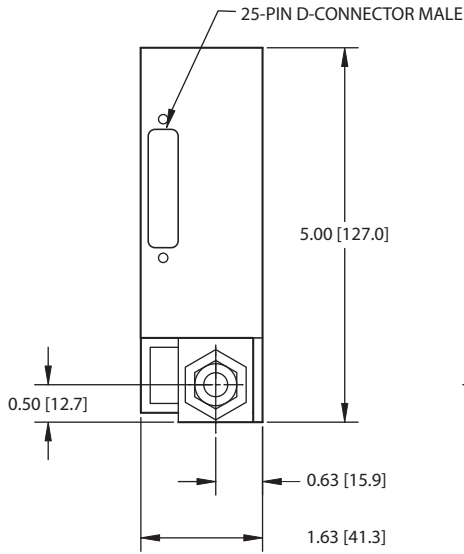

DFM26 and DFM27

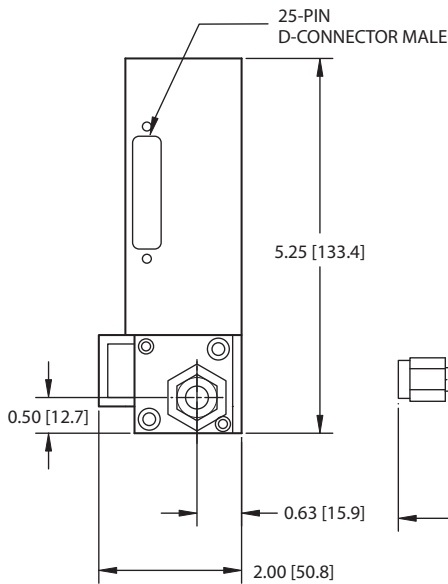
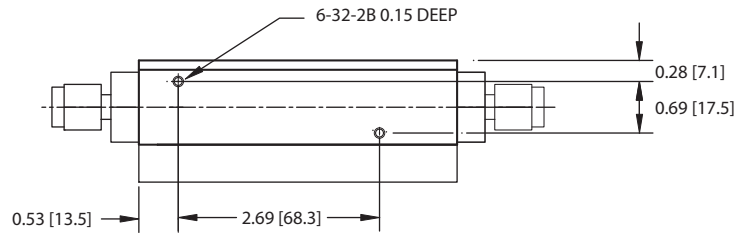
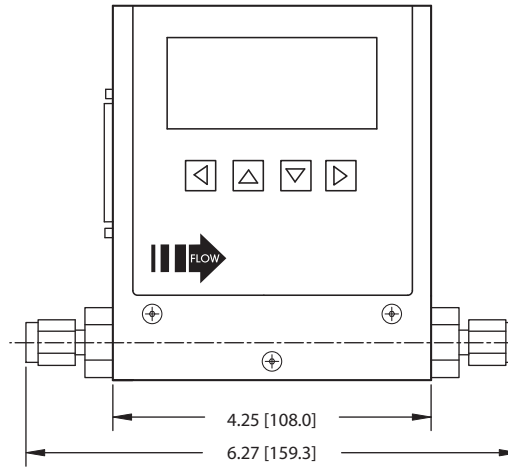

**DFM36 and DFM37
DFM46 and DFM47**

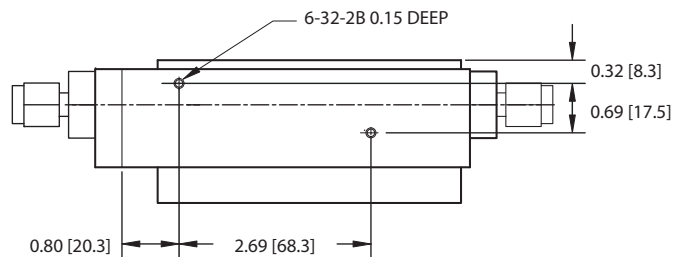
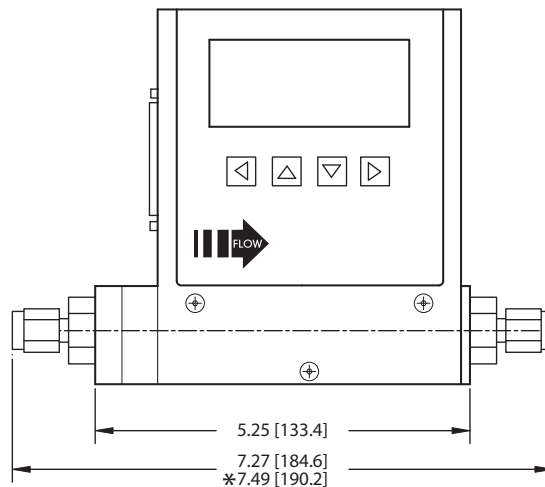

*FOR HIGH FLOW MASS FLOW METER



DFM	MODEL
SERIES	MAX FLOW (N ₂)
26	10 L/min
36	50 L/min
46	100 L/min
27	10 L/min
37	50 L/min
47	100 L/min
MATERIAL	
S	Stainless Steel

SEALS	
V	Viton®
B	Buna®
E	EPR
T	PTFE / Kalrez®

FITTINGS	MODEL
A	1/4" Compression
B	1/8" Compression
C	1/4" VCR®
D	3/8" Compression
H	6mm Compression

DISPLAY	
L	LCD readout

POWER	
2	12 Vdc
4	24 Vdc
5	±15 Vdc

OUTPUT SIGNAL	
A	0-5 Vdc
B	4-20 mA
C	0-10 Vdc

TEMP & PRESSURE OUTPUT SIGNAL (A only 26, 36, 46)		
CODE	TEMP OUT	PRESSURE OUT
A	n.a.	n.a.
B	0-5Vdc	0-5Vdc
C	0-5Vdc	4-20mA
D	0-5Vdc	0-10Vdc
E	4-20mA	0-5Vdc
F	4-20mA	4-20mA
G	4-20mA	0-10Vdc
H	0-10Vdc	0-5Vdc
I	0-10Vdc	4-20mA
J	0-10Vdc	0-10Vdc

**DIGITAL INTERFACE	
2	RS232
5	RS485

****RS485** is standard. No cost optional **RS232** is selected by changing the last digit of part number from 5 to 2.

LABELS	
A	Aalborg

*n.a. = not applicable.

DFM 36 S - V A L 5 - A A 5 A

EXAMPLE: DFM36S-VAL5-AA5 50 L/min [N₂] 20 psig

SPECIFY: FLOW RANGE, GAS and PRESSURE

DFM36 stainless steel, Viton® seals, 1/4" compression fittings, LCD readout display, ±15 Vdc power, 0-5Vdc output signal, RS485 digital interface.

Model **AF** mass flow controllers are designed to indicate flow rates and control set flow rates of gases.

Each of these units incorporates an advanced straight tube sensor in conjunction with flow passage elements constructed of stainless steel.

LCD readouts of command modules are supplied with 0 to 100 percent calibrations. Zero and span adjustments are conveniently accessible from outside of the transmitters.

Design Features

- Rigid metallic construction.
- Maximum pressure of 1000 psig (70 bars).
- 0-5 Vdc or 4-20mA signals.
- Leak integrity 1×10^{-9} smL/sec of helium.
- Accuracy of $\pm 1\%$ F.S.
- Totalizer option.
- Circuit protection.

Principles of Operation

Metered gases are divided into two laminar flow paths - one through the primary flow conduit and the other through a capillary sensor tube.

Both flow conduits are designed to ensure laminar flows and therefore the ratio of their flow rates is constant.

Two precision temperature sensing windings on the sensor tube are heated, and when flow takes place, gas carries heat from the upstream to the downstream windings. The resultant temperature differential is proportional to the change in resistance of the sensor windings.

A Wheatstone bridge design is used to monitor the temperature dependent resistance gradient on the sensor windings which is linearly proportional to the instantaneous rate of flow.

Output signals of 0 to 5Vdc or 4 to 20mA are generated indicating mass molecular based flow rates of the metered gas.

SDPROC and AFC Analog Mass Flow Controller



In AFC mass flow controllers the combined gas streams flow through a proportionating electromagnetic valve with an appropriately selected orifice. The closed loop control circuit continuously monitors the mass flow output and maintains it at the set flow rate.

Flow rates are unaffected by temperature and pressure variations within stated limitations.

Transducer power supply ports are fuse and polarity protected.

AFC mass flow controllers include an electromagnetic control valve that allows the flow to be set to any desired

flow rate within the range of the particular model. The valve is normally closed as a safety feature to ensure that gas flow is shut off in case of a power outage.

AF mass flow controllers are designed to meter and control flow rates of gases.

AF mass flow controllers are available with flow ranges from 10 mL/min to 100LPM [N₂]. Gases are connected by means of 1/4", 3/8", or optional 1/8" compression fittings.

These controllers may be used as bench top units or mounted by means of screws in the base.

TABLE 26 - SPECIFICATIONS

ACCURACY:	±1% of FS at calibration temperature and pressure.
CALIBRATIONS:	Performed at standard conditions [14.7 psia (101.4 kPa) and 70 °F (21.1°C)] unless otherwise stated.
REPEATABILITY:	±0.25% of full scale.
TIME CONSTANT:	AFC26: (Q _{max} = 10 L/min): 300 ms. AFC36: (Q _{max} = 50 L/min): 600 ms. AFC46: (Q _{max} = 100 L/min): 600 ms.
RESPONSE TIME:	AFC26: (Q _{max} = 10 L/min): Approximately 1 second to within ±2% of set flow rate for 25% to 100% of full scale flow. AFC36: (Q _{max} = 50 L/min) and AFC46: (Q _{max} =100 L/min): Approximately 2 second to within ±2% of set flow rate for 25% to 100% of full scale flow.
TEMPERATURE COEFFICIENT:	0.1% of full scale/ °C.
PRESSURE COEFFICIENT:	0.01% of full scale/psi (0.07 bar).
OPTIMUM GAS PRESSURE:	25 psig (1.73 bars).
MAXIMUM GAS PRESSURE:	1000 psig (70 bars) maximum. Standard calibration is at 20 psig (1.4 bars) inlet pressure.
MAX. PRESSURE DROP: (at full scale flow)	Refer to Table 29.
GAS AND AMBIENT TEMPERATURE:	32 °F to 122 °F (0 °C to 50 °C). 14 °F to 122 °F (-10 °C to 50 °C) - Dry gases only.
LEAK INTEGRITY:	1 x 10 ⁻⁹ smL/sec of helium maximum, to the outside environment.
**MATERIALS IN FLUID CONTACT:	316 stainless steel, 416 stainless steel, Viton® O-rings. Optional O-rings: Buna®, EPR and Kalrez®.
ATTITUDE SENSITIVITY:	No greater than ±15 degree rotation from horizontal to vertical; standard calibration is in horizontal position.
OUTPUT SIGNALS:	Linear 0-5 Vdc (2000 W min. load impedance); 4 - 20 mA optional (0 - 500 Ω loop resistance); maximum noise 20 mV peak to peak.
CONNECTIONS:	AFC26: 1/4" compression fittings. <i>Optional:</i> 6mm, 3/8" and 1/8" compression fittings or 1/4" VCR®. AFC36: 1/4" compression fittings. <i>Optional:</i> 6mm and 3/8" compression fittings or 1/4" VCR®. AFC 46: 3/8" compression fittings.
TRANSDUCER INPUT POWER:	AFC 26: +15 ±5% Vdc, 80 mA max, 1.2W; -15 ± 5% Vdc, 200 mA max, 3W; AFC 36 /AFC 46: +15 ±5% Vdc, 220 mA max, 3.3W; -15 ±5% Vdc, 600 mA max, 9W.
CIRCUIT PROTECTION:	Circuit boards have built-in polarity reversal protection. Replaceable fuses provide power input protection.

***The selection of materials of construction, is the responsibility of the customer. The company accepts no liability.*

Leak Integrity

1 x 10⁻⁹ smL/sec of helium max to outside environment.

Mass Flow Systems

Complete Mass Flow Systems include Command Modules, transducers and cables. Command modules contain appropriate power supplies, 24x2 alpha-numeric dot matrix display read-out, and four panel buttons which provide complete control over all the various functions necessary to measure and/or control flow.

Optional built in Ethernet interface allows accessing any Internet-connected SDPROC from a browser on your work station, PC, or laptop computer.

TABLE 27 - FLOW RANGES FOR AFC

AFC 26	
CODE	UNITS [NITROGEN]
01	0 to 10 mL/min
02	0 to 20 mL/min
03	0 to 50 mL/min
04	0 to 100 mL/min
05	0 to 200 mL/min
06	0 to 500 mL/min
07	0 to 1 L/min
08	0 to 2 L/min
09	0 to 5 L/min
10	0 to 10 L/min
AFC 36	
11	0 to 15 L/min
30	0 to 20 L/min
31	0 to 30 L/min
32	0 to 40 L/min
33	0 to 50 L/min
AFC 46	
40	0 to 60 L/min
41	0 to 80 L/min
42	0 to 100 L/min

TABLE 28 - MAXIMUM PRESSURE DROP FOR AFC

FLOW RATE [liters/min]	AFC SERIES	
	[psid]	[bars]
up to 10	1.06	0.072
up to 15	3.87	0.26
up to 20	2.0	0.136
up to 30	3.5	0.238
up to 40	5.5	0.374
up to 50	8	0.544
up to 100	18.9	1.302



BULLETIN EM201412AFC

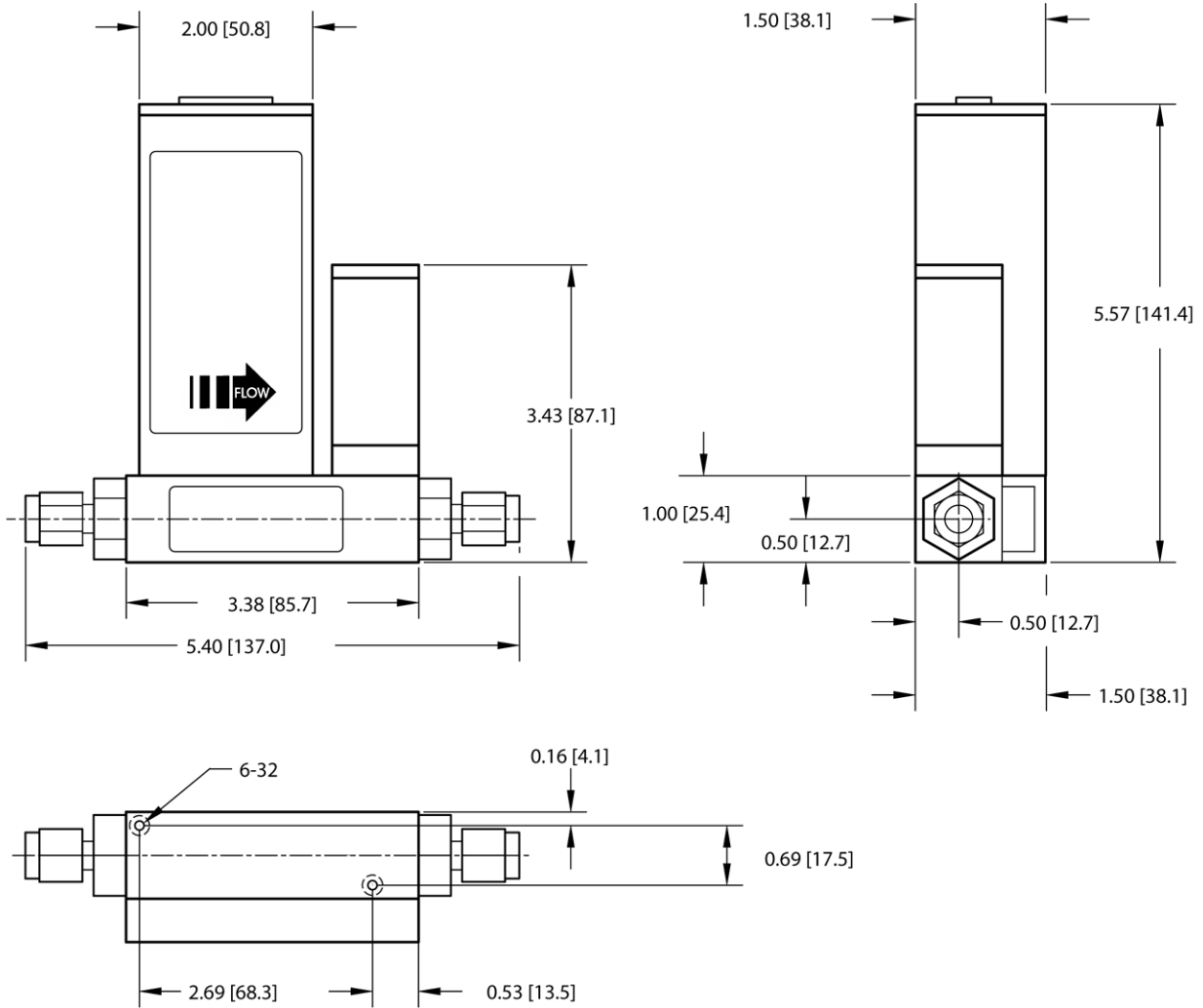

DIMENSIONS: INCH [mm]

AFC26
Analog Mass Flow Controller

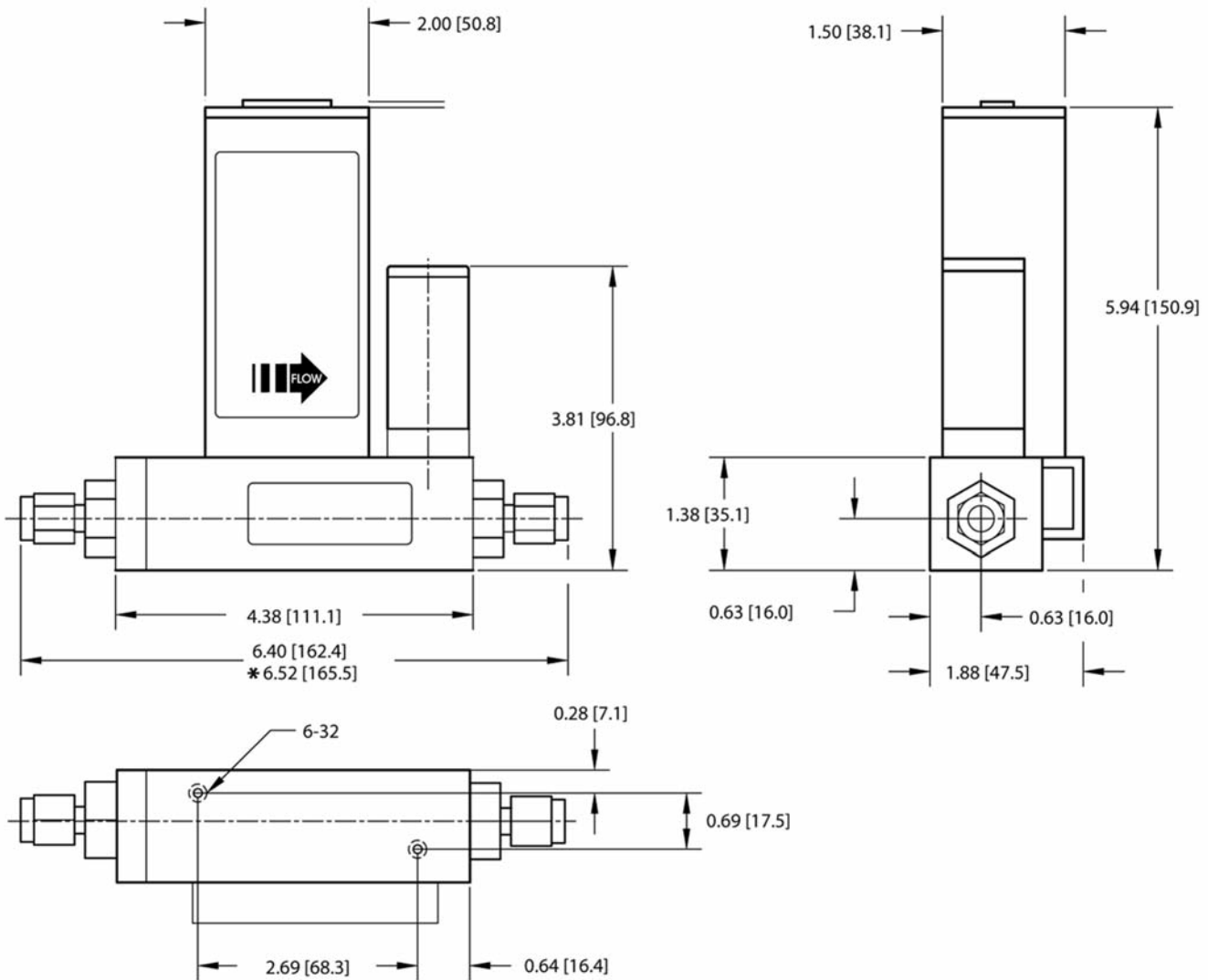

DIMENSIONS: INCH [mm] *FOR HIGH FLOW MASS FLOW CONTROLLER ONLY

AFC36 / AFC46
Mass Flow Controller



MODEL			
AFC			
SERIES	MAX. FLOW (N ₂)		
26	10 L/min		
36	50 L/min		
46	100 L/min		
MATERIAL			
S	Stainless Steel		
SEALS			
V	Viton®		
B	Buna®		
E	EPR		
T	PTFE / Kalrez®		
FITTINGS		MODEL	
A	1/4" Compression	AFC 26, 36	
B	1/8" Compression	AFC 26, 36	
C	1/4" VCR®	AFC 26, 36	
D	3/8" Compression	AFC 26, 36, 46	
H	6mm Compression	AFC 26, 36	
DISPLAY			
N	No Display		
POWER			
5	±15 Vdc		
INPUT / OUTPUT SIGNAL			
C	0-5Vdc / 0-5Vdc		
D	0-5Vdc / 4-20mA		
DIGITAL INTERFACE			
0	NONE		

AFC 36 S — V A N 5 — A 0

EXAMPLE: AFC36S-VAN5-A0 50 L/min [N₂] 20 psig
SPECIFY: GAS, FLOW RANGE and PRESSURE.

AFC36 stainless steel, Viton® seals with 1/4" compression fittings, without a display, ±15 Vdc, *n.a./0-5Vdc input/output signal, and no digital interface.

Smart Digital Command Module



SDPROC

Microprocessor driven digital Command Modules are used in conjunction with any analog or digital mass flow controllers with 0-5 Vdc input /output signals. One, two, three and four channel Command Module configurations are available. Command Modules contain appropriate power supplies, 24x2 alpha-numeric dot matrix display readout, and four panel buttons which provide complete control over all the various functions necessary to measure and/or control flow.

Programming

It is easy to program the SMART DPROC using a logically organized, modular menu. The operator quickly accesses a desired function by branching through the multi-level tree structure, rather than scrolling through the entire menu. RS-232 serial communication interface is standard for all models and supported via a 9 pin "D"-connector on the back panel of the Command Module. RS-232 Software interface commands set allows communications with the unit using either a custom software program or a "dumb terminal" and provide complete control over all modes and functions.

PROGRAMMABLE BATCH FLOW CONTROL

The Batch Flow Control allows execution of custom, user preset program of up to sixteen steps. During execution of the program the user can activate or deactivate the LOOP mode. Various flow configurations may be preprogrammed: ramping, pulsing, linearized increasing and/or decreasing of the flow.

Optional built-in Ethernet interface allows accessing any Internet-connected SDPROC from a browser on your work station, PC, or laptop computer.

Regardless of where you are, your Command Module is as close as the nearest browser! There are two levels of Ethernet based Remote Controls: HTML web server and TELNET. The HTML web server, which is hosted on the Command Module lets one view CURRENT FLOW RATE, CONTROL VALVE MODE and/or SET POINT, MONITOR TOTALIZER READING FOR SELECTED CHANNEL. The TELNET console provides complete control over all modes and functions and using the same Software interface commands set as the RS-232 communication interface.

Design Features

ENGINEERING UNITS

The flow set points, measured gas flow and associated totalizer data are scaled directly in engineering units via front panel keypad, RS-232 or Ethernet interface.

The following units of measure are supported:

%F.S., SLPM, L/s, mL/min, mL/h, SCFM, SCFH, SCMM, SCMH, LBPM, LBPH, GRPM, GRPH.

USER SELECTABLE REFERENCE FOR SET POINT

The INTERNAL, EXTERNAL, PROGRAM refers to the point of origin for the Set Point signal.

In INTERNAL REFERENCE MODE, the user sets the control signal with SDPROC controls (via front panel keypad, RS-232 or Ethernet interface).

In EXTERNAL REFERENCE MODE, the user sets the control signal from a remote location (via the DATA IN/OUT 25-pin "D"-connector on the rear panel).

In PROGRAM MODE the set point signal will be driven by user's custom program stored in the EEPROM. There are three Program modes: BATCH, TIMER and RATIO*.

*RATIO mode not available for one channel module.

PROGRAMMABLE TIMER FLOW CONTROL

The Timer Flow Control allows execution of custom, user preset program of up to 96 steps.

Each step can be preprogrammed for a particular date, time, and set point value. Every step has two fields: starting date, time and set point in % F.S.

RATIO FLOW CONTROL

The Ratio Flow allows controlling flow of the mixture of up to four different gases (for 4 channel Command Module) with preset values of the ratio in % for each channel. The flow rate of the mixture can be incremented or decremented by changing the set point of the master channel #1.

FLOW ALARMS

High and Low gas flow ALARM limits can be preprogrammed for each channel. ALARM conditions become true when the difference between current readings and installed set points are equal or more than corresponding values of high and low alarm levels.

Alarm action can be assigned with preset delay interval (0-3600 seconds) to one of the following:

- Contact closer (separate for High and Low alarm).
- Buzzer audible signal.
- Valve shut down (Close).

CONTACT CLOSURES

Two sets of dry contact relay outputs for each channel are provided to actuate user supplied equipment. The relays can be assigned to switch when a specified event occurs (e.g. when a low or high flow alarm limit is exceeded or when the totalizer reaches a specified value).

TOTALIZER

The total volume of the gas is calculated by integrating the actual gas flow rate with respect to time.

Both keypad menu and digital interface commands are provided to:

- Set the totalizer to ZERO.
- Start the totalizer at a preset flow.
- Assign action at a preset total volume.
- Start/Stop totalizing the flow.
- Read totalizer.

Totalizer conditions become true, when the totalizer, and the "Stop at Total" volumes are equal.

Totalizer action can be assigned to one of the following:

- Contact closer.
- Buzzer audible signal.
- Valve shut down (Close).

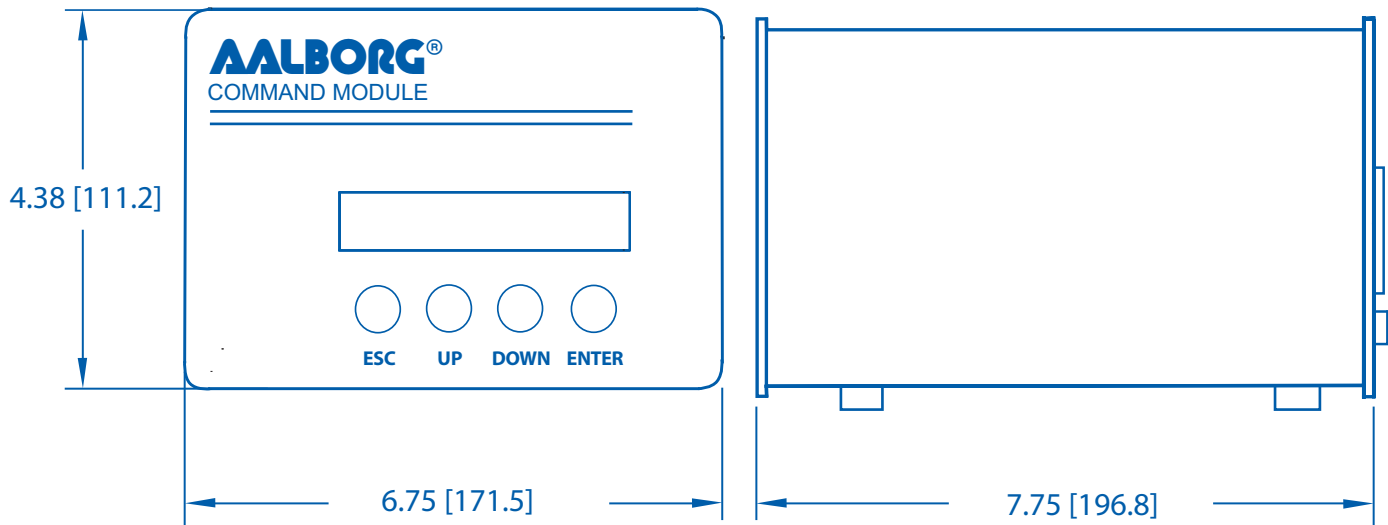

DIMENSIONS SHOWN IN BRACKETS ARE IN MILLIMETERS

TABLE 29 - SPECIFICATIONS	
ENVIRONMENTAL (per IEC 664)	Installation Level II; Pollution degree II.
POWER SUPPLY:	85 to 240 VAC (47 to 440 Hz); 120 to 370 VDC 2A max.
FUSE:	2A on input power line. When changing, unplug the device from power source. Replace only with fuse 5mm 2A/250V FF.
DISPLAY:	24 x 2 LCD dot matrix with backlight; 24x2 Vacuum Fluorescent display optional.
ADC/DAC RESOLUTION:	12 bits (0.025%).
COMMUNICATION STANDARD:	RS-232 9600 baud rate, 8 bits, two stop bits, no parity (8,2,N).
OPTIONAL:	Ethernet TCP/IP. (HTML Server or TELNET Console).
DIMENSIONS:	Length: 7.75" (19.5 cm), width: 6.75" (17 cm), height: 4.5" (11cm).
WEIGHT:	4.5 lbs (2 kg).
INTERFACE CABLE:	Flat cable with male 15-pin "D" connector and female 15-pin "D" connector on the ends is standard. Optional round shielded cable is available with male/female 15-pin "D" connector ends. [Cable length may not exceed 9.5 feet (3 meters)]
DATA PORT AND RELAY CABLE:	Optional shielded cable with male 25-pin "D" connector to connect to command module data and relay ports. [Cable length may not exceed 9.5 feet (3 meters)].

BULLETIN EM201412 SDPROC

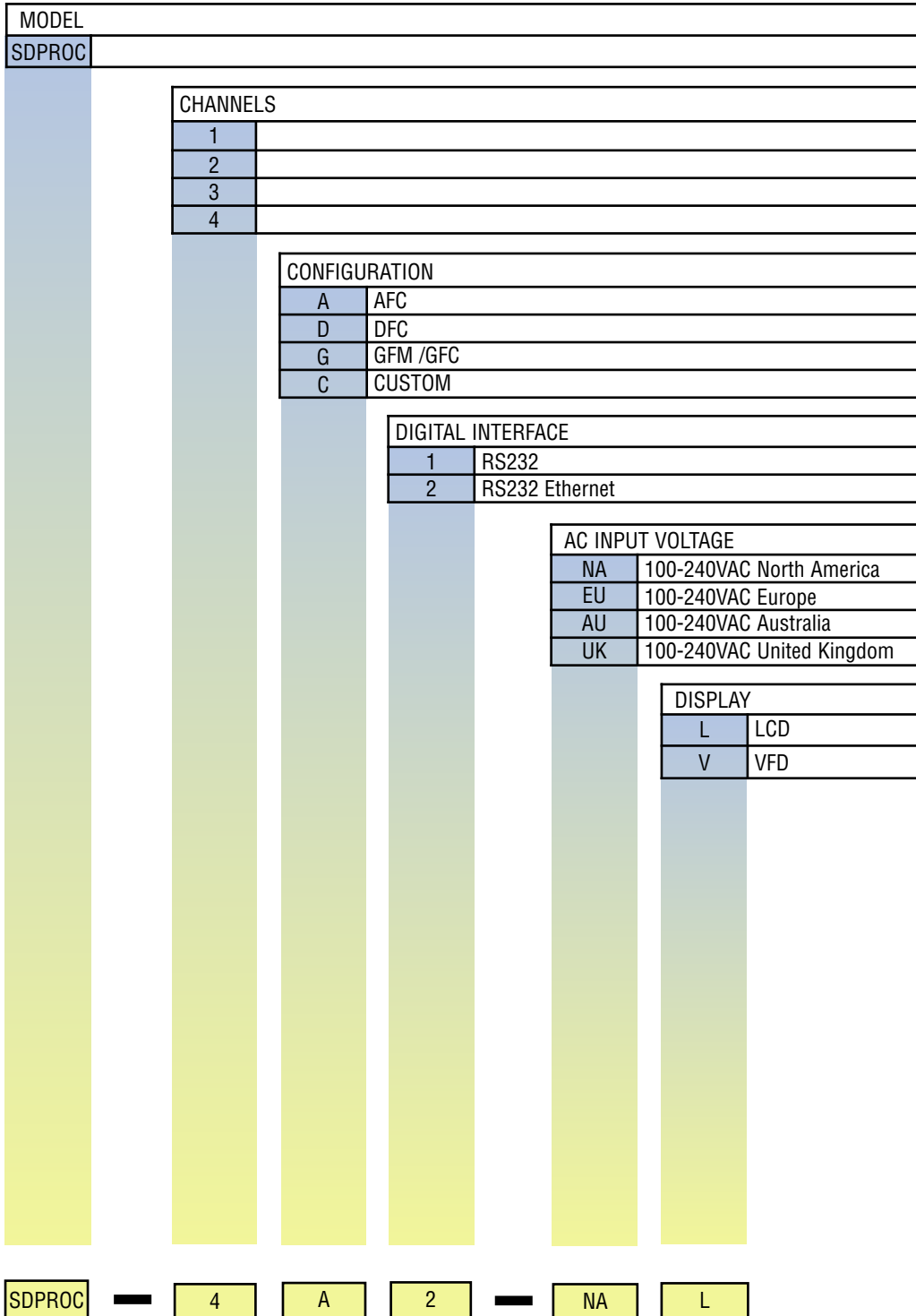

EXAMPLE: SDPROC-4A2-NAL

Smart Digital Command Module, 4-Channel, AFC configuration, RS232 with Ethernet, 100-240 VAC North America plug, LCD display.

Design Features

- Flow meters for liquid flow applications.
- Jewel bearings allow for very low minimum flow rates.
- Easy to install and operate.
- Mounted horizontally or vertically.
- Only one moving part.
- Flow indication via transparent acrylic cover.
- Versatile square wave flow output signal.
- Female NPT ports.
- Multiparameter: flow and temperature *outputs. Four wires platinum RTD option.
- Polypropylene and chemically resistant PVDF models.

* PWM provides only raw pulse output signals. In order to get actual flow and temperature readings, user has to implement additional signal processing.

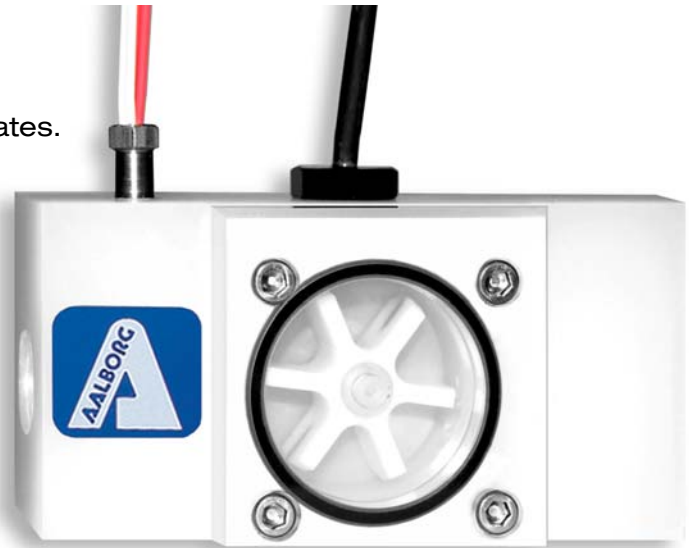

FOR LIQUIDS ONLY

Principles of Operation

Fluid flowing through the unit causes the paddle wheel to spin. As the magnets embedded in the paddle spin past the sensor, electrical pulses are produced in which frequency is proportional to the flow rate. The number of pulses per desired time interval and the K-factor (number of pulses/gallon) make it possible to calculate the flow rate and volume passing through the unit.

TABLE 30 - FLOW RATE FOR PWM

METER SIZES	FLOW RATE H ₂ O		Inlet/Outlet Ports Female NPT	Max Pressure Drop	
	[L/min]	[gal/min]		Bar	PSI
PWM4	0.15-18.9	0.04-5	3/8"	1	15
PWM6	0.3-37.6	0.08-10	1/2"	1.4	20
PWM8	0.6-64.4	0.15-17	3/4"	1.4	20
PWM10	1.3-132.5	0.35-35	1"	1.4	20

TABLE 32 - PADDLE WHEEL MODEL NUMBERS

POLYPROPYLENE	POLYPROPYLENE with RTD	PVDF	PVDF with RTD
PWM4P	PWM4PR	PWM4T	PWM4TR
PWM6P	PWM6PR	PWM6T	PWM6TR
PWM8P	PWM8PR	PWM8T	PWM8TR
PWM10P	PWM10PR	PWM10T	PWM10TR

TABLE 31 - SPECIFICATIONS

ACCURACY	±1% FS.
MAX TEMPERATURE	60 °C (140 °F).
MAX PRESSURE	10 barg (150 psig).
POWER	5 to 24 Vdc @ 2 mA.
OUTPUT SIGNAL	NPN open collector (load 30 mA max).
DIMENSIONS	56H x 108L x 53D [mm] (2.2 x 4.25 x 2.2") Without RTD and flow sensors.
CABLE	Flow signal 1.8 m (6') or optional 3.7m (12') [ft.] RTD 12 [in.] long cable.
RTD	Platinum 0.00385 TCR, meets EN 60751, Class B.

TABLE 33- WETTED MATERIALS

	POLYPROPYLENE MODELS	PVDF UNITS MODELS
BODY	Polypropylene	PVDF
LID	Acrylic	PVDF
PADDLE WHEEL	PVDF	PVDF
SHAFT	Nickel Tungsten Carbide	Zirconia Ceramic
BEARINGS	Sapphire Jewels	Sapphire Jewels
O-RINGS	EPDM	PTFE
PLATINUM RTD	316 ss casing	316 ss casing

FOR LIQUIDS ONLY



**PLEASE NOTE:
POWER CORD WITH MALE PLUG IS NOT INCLUDED.
ORDER SEPARATELY: CAT NO. CBL-PWE**

Design Features

- Jewel bearings allow for very low minimum flow rates.
- Multiparameter: flow and optional temperature measurements.
- Polypropylene and chemically resistant PVDF models.
- Supports up to 29 Engineering Units (including User Defined).
- Two programmable Totalizers and Flow Pulse output (3.3Vdc CMOS).
- Programmable High/Low Flow and optional Temperature Alarms with preset action delay interval.
- Two sets of user-programmable optically isolated outputs.
- User-selectable (via jumpers) analog 0-5 Vdc or 4-20mA flow and optional temperature outputs.
- RS-232 or RS-485 Digital Interface with Multi-Drop Capability of up to 256 units (RS-485 option).
- Local key pad and 2x16 characters LCD display with adjustable back light (optional).
- Enclosure weather tight to IP65 standards.
- Free communication software with temperature and flow data log-in capability.

General Description

PWE flow meters support various functions including: two independently programmable flow totalizers, user programmable low, high or range flow and temperature alarm, two sets of user programmable optically isolated outputs, self diagnostic alarm, flow pulse output.

The flow rate can be displayed in 29 different volumetric or mass flow engineering units. Flow meter parameters and functions can be programmed locally via optional key pad and LCD[†] or remotely via the RS-232/RS-485 interface.

Optional local 2x16 LCD[†] readout with adjustable back light provides flow rate, temperature[†], total volume reading in currently selected engineering units, diagnostic events indication and feature a password protected access to the process parameters to ensure against tampering or resetting.

(† - optional feature)

Principles of Operation

Liquid flowing through the unit causes the paddle wheel to spin. As the magnets embedded in the paddle spin past the sensor, electrical pulses are produced in which frequency is proportional to the flow rate. The number of pulses per desired time interval and the K-factor (number of pulses/gallon) make it possible to calculate the flow rate and volume passing through the unit.

On board CPU and signal conditioner circuitry perform accurate flow and total computation, digital communication and analog 0-5 Vdc or 4-20 mA output signals. Non-volatile memory stores all hardware specific and user programmable variables, including flow linearization table.

Totalizer

The total volume of the liquid is calculated by integrating the actual liquid flow rate with respect to time. The optional LCD/keypad and digital interface commands are provided to:

- set the totalizer to ZERO
- start the totalizer at a preset flow
- assign action at a preset total volume
- start/stop totalizing the flow
- read totalizer

Totalizer conditions become true, when the totalizer reading and the “Stop at Total” volumes are equal. Main Totalizer reading is stored in the non volatile memory (EEPROM). The pilot Totalizer reading is stored in volatile memory (SRAM) and will be lost if flow meter is powered down.

Engineering Units

The measured flow and associated totalizer data are scaled directly in engineering units via the digital interface.

THE FOLLOWING 29 UNITS OF MEASURE ARE SUPPORTED:

TABLE 34 - UNITS OF MEASURE				
NUMBER	INDEX	FLOW RATE ENGINEERING UNITS	TOTALIZER ENGINEERING UNITS	DESCRIPTION
1	0	%	%s	percent of full scale
2	1	mL/s	mL	milliliter per second
3	2	mL/min	mL	milliliter per minute
4	3	mL/h	mL	milliliter per hour
5	4	l/s	ltr	liter per second
6	5	l/min	ltr	liter per minute
7	6	l/h	ltr	liter per hour
8	7	m ³ /s	m ³	cubic meter per second
9	8	m ³ /min	m ³	cubic meter per minute
10	9	m ³ /h	m ³	cubic meter per hour
11	10	ft ³ /s	ft ³	cubic feet per second
12	11	ft ³ /min	ft ³	cubic feet per minute
13	12	ft ³ /h	ft ³	cubic feet per hour
14	13	gal/s	gal	gal per second
15	14	gal/min	gal	gal per minute
16	15	gal/h	gal	gal per hour
17	16	g/s	g	grams per second
18	17	g/min	g	grams per minute
19	18	g/h	g	grams per hour
20	19	kg/s	kg	kilograms per second
21	20	kg/min	kg	kilograms per minute
22	21	kg/h	kg	kilograms per hour
23	22	lb/s	lb	pounds per second
24	23	lb/min	lb	pounds per minute
25	24	lb/h	lb	pounds per hour
26	25	t/s	ton	ton (metric) per sec
27	26	t/min	ton	ton (metric) per minute
28	27	t/h	ton	ton (metric) per hour
29	28	User	UD	user defined

Flow and Temperature[†] Alarms

High and Low flow ALARM limits can be preprogrammed via digital interface or optional LCD/Keypad. ALARM conditions become true when the current reading is equal or higher/lower than corresponding values of high and low alarm levels. Alarm action can be assigned with preset delay interval (0-3600seconds) to activate the optically isolated output (separate for High and Low alarm). Latch Mode control feature allows each optical output to be latched on or follow the corresponding alarm status.

(† - optional feature)

Optically Isolated Outputs

Two sets of optically isolated outputs are provided to actuate user supplied equipment. These are programmable via digital interface or optional LCD/Keypad such that the outputs can be made to switch when a specified event occurs (e.g. when a low or high flow alarm limit is exceeded or when the totalizer reaches a specified value) or may be directly controlled by user.

TABLE 35 - FLOW RATE FOR PWE

METER SIZES	FLOW RATE H ₂ O		INLET/OUTLET PORTS FEMALE NPT	MAXIMUM PRESSURE DROP	
	[L/min]	[gal/min]		Bar	PSI
PWE4	0.15-18.9	0.04-5	3/8"	1	15
PWE6	0.3-37.6	0.08-10	1/2"	1.4	20
PWE8	0.6-64.4	0.15-17	3/4"	1.4	20
PWE10	1.3-132.5	0.35-35	1"	1.4	20

TABLE 36 - WETTED MATERIALS

	POLYPROPYLENE MODELS	PVDF MODELS
BODY	Polypropylene	PVDF
LID	Acrylic	PVDF
PADDLE WHEEL	PVDF	PVDF
SHAFT	Nickel Tungsten Carbide	Zirconia Ceramic
BEARINGS	Sapphire Jewels	Sapphire Jewels
O-RINGS	EPDM	PTFE
PLATINUM RTD	316 stainless steel casing	316 stainless steel casing

TABLE 37 - DIGITAL PADDLE WHEEL FLOW METER ACCESSORYS

MODEL NO.	DESCRIPTION
CBL-PWE	Cable 12 Pins stripped end 6 foot shielded
PS-PWE-110NA-2	Power Supply PWE 110 Vac North American Plug
PS-PWE-230EU-2	Power Supply PWE 230 Vac Continental Plug
PS-PWE-240AU-2	Power Supply PWE 240 Vac Australian Plug
PS-PWE-240UK-2	Power Supply PWE 240 Vac UK Plug

TABLE 38 - DIGITAL PADDLE WHEEL METER FEATURES FOR POLYPROPYLENE MODELS

NO KEY PAD & LCD - NO RTD	WITH RTD - NO KEY PAD & LCD	KEY PAD & LCD - NO RTD	KEYPAD & LCD - RTD
PWE04P(*)NN	PWE04P(*)NR	PWE04P(*)LN	PWE04P(*)LR
PWE06P(*)NN	PWE06P(*)NR	PWE06P(*)LN	PWE06P(*)LR
PWE08P(*)NN	PWE08P(*)NR	PWE08P(*)LN	PWE08P(*)LR
PWE10P(*)NN	PWE10P(*)NR	PWE10P(*)LN	PWE10P(*)LR

TABLE 39 - DIGITAL PADDLE WHEEL METER FEATURES FOR PVDF MODELS

NO KEY PAD & LCD - NO RTD	WITH RTD - NO KEY PAD & LCD	KEY PAD & LCD - NO RTD	KEYPAD & LCD - RTD
PWE04T(*)NN	PWE04T(*)NR	PWE04T(*)LN	PWE04T(*)LR
PWE06T(*)NN	PWE06T(*)NR	PWE06T(*)LN	PWE06T(*)LR
PWE08T(*)NN	PWE08T(*)NR	PWE08T(*)LN	PWE08T(*)LR
PWE10T(*)NN	PWE10T(*)NR	PWE10T(*)LN	PWE10T(*)LR

(*) FOR COMPLETE MODEL NUMBERS SEE PAGE 60.

TABLE 40 - SPECIFICATIONS FOR PWE

FLOW MEDIUM:	Please note that PWE Flow Meters are designed to work only with liquids. Never try to measure flow rates of dry gas.
CALIBRATIONS:	Performed at standard conditions [14.7 psia (101.4 kPa) and 70 °F (21.1 °C)] unless otherwise requested or stated.
VISCOSITY:	Calibrated to 1 cSt (water) meters with display can be used for liquids up to 50 cSt with field calibration (maximum flow range may be affected).
ENVIRONMENTAL (PER IEC 664):	Installation Level II; Pollution Degree II.
FLOW ACCURACY (INCLUDING LINEARITY):	±1% of FS.
REPEATABILITY:	±0.25% of full scale.
LIQUID TEMPERATURE MEASUREMENT RANGE†:	34 °F to 140 °F (1 °C to 60 °C).
TEMPERATURE ACCURACY (INCLUDING LINEARITY)†:	±0.5 °C.
FLOW RESPONSE TIME:	Approximately 1 seconds (above 10% of full scale flow), approximately 2 seconds (below 10% of full scale flow).
MAXIMUM PRESSURE:	10 barg (150 psig).
MAXIMUM PRESSURE DROP:	1.4 bar (20 psi) at 132.5 L/min flow. See table 35 for pressure drops associated with various models and flow rates.
AMBIENT TEMPERATURE RANGE:	14 °F to 140 °F (-10 °C to 60 °C).
OUTPUT SIGNALS:	Linear 0-5 Vdc (3000 ohms min load impedance); Linear 4-20 mA (500 ohms maximum loop resistance). Maximum noise 20mV peak to peak (for 0-5 Vdc output).
FLOW PULSE OUTPUT:	3.3 Vdc amplitude (3000 ohms min load impedance).
OPTICALLY ISOLATED OUTPUTS:	UCE 40Vdc, ICE 150 mA.
FLOW METER INPUT POWER:	11 to 26 Vdc, 100 mV maximum peak to peak output noise. Power consumption: +12Vdc (150 mA maximum); +24Vdc (100 mA maximum); Circuit board have built-in polarity reversal protection, 300mA resettable fuse provide power input protection.
COMMUNICATIONS PARAMETERS (RS-232/RS-485):	Baud rate: 9600 baud. Stop bit: 1. Data bits: 8. Parity: None. Flow Control: None.
ELECTRICAL CONNECTIONS:	Built-in female 12 pin M16, IP67 connector. To be mated with 12 pin M16 male EMI shielded IP67 connector. (binder P/N: 99-5629-15-12) not included. Optional cable available. Cable including male connector available.
DISPLAY†:	Optional local 2x16 characters LCD with adjustable backlight (2 lines of text).
KEY PAD†:	Optional 4 push button key pad.
CE COMPLIANT:	EMC Compliance with 89/336/EEC as amended. Emission Standard: EN 55011:1991, Group 1, Class A Immunity Standard: EN 55082-1:1992

(† - optional feature)

PWE	MODEL								
ORIFICE SIZE (Maximum Flow Range)									
04	5 gal / min (0.15 - 18.9 L/min)								
06	10 gal / min (0.3 - 37.6 L/min)								
08	17 gal / min (0.6 - 64.4 L/min)								
10	35 gal / min (1.3 - 132.5 L/min)								
MATERIAL LOWER BLOCK									
P	Polypropylene								
T	PVDF								
SEALS									
E	EPDM								
T	PTFE								
B	Buna®								
V	Viton®								
DISPLAY / KEYPAD									
N	No Display / No Key Pad								
L	LCD / Key Pad								
RTD OPTION									
N	No RTD								
R	RTD								
OUTPUT SIGNAL									
A	0-5 VDC								
B	4-20 mA								
DIGITAL INTERFACE									
2	RS-232								
5	RS-485								
PWE	04	P	—	E	L	N	—	A	2

EXAMPLE: PWE04P-ELN-A2

Digital Paddle Wheel Meter, Maximum Flow 5 Gal. per minute, Polypropylene Lower Block, EPDM Seals, LCD Key Pad, No RTD, 0-5 Output Signal with RS-232 Digital Interface.



For Multi-Parameter Meters see mVX

Design Features

- No moving parts to wear or fail.
- Electronics can be remotely mounted up to 30.5 m (100 ft).
- No fluid to sensor contact.
- No holes to clog.
- Aalborg's proprietary DSP algorithm accurately filters vortex frequency.
- High flow turndown ratio up to 10:1.
- Dual signal processing technology improves accuracy at low flows.
- Accuracy of $\pm 1\%$ of rate.
- Noise cancellation technology.
- Extensive Diagnostics.
- Password protected data entry.
- Volumetric and mass flow information simultaneously displayed.
- Selectable engineering units.
- On board computer calculates density and mass flow.
- Two programmable totalizers.

Principles of Operation

Vortices are created when a fluid passes around a bluff body as shown in Figure 1. Vortices are alternately shed on each side of the body, 180 degrees out of phase to each other, resulting in an oscillating pressure gradient. As flow increases the frequency of vortices increases in proportion to the increased flow thereby creating a linear relationship.

General Description

Constructed of type 316 stainless steel, wafers may be installed in-line by customer provided or built-in flanges. Key pad or communication interface functionalities include measuring units, programmable flow alarm, two programmable totalizers, programmable flow rate pulse output, two programmable optically isolated outputs, battery backed real time clock (RTC), digital communication interface (RS-232 or RS-485), programmable diagnostic events log and register with date and time stamp, programmable process variable log with date stamp, calibration and flowing fluid parameters adjustment, extensive diagnostics.

Our exclusive dual signal processing technology independently measures each vortex on either side of the bluff body and filters out non-flow noise. This results in less noise and higher accuracy throughout the flow range. Aalborg's proprietary DSP algorithm accurately filters vortex frequency, improving the quality of flow measurements.

Local 2x16 LCD readout provides flow rate and total flow volume reading in selectable engineering units, diagnostic events indication and feature a password protected access to the process parameters to ensure against tampering or resetting.



Vortex In-line Flow Meter Shown with Wafer Mounting

Vortex In-line Flow Meter Shown with Flange Mounting

TABLE 41 - FUNCTIONAL SPECIFICATIONS

FLUID TYPES	Steam, Gas, Liquid.
MAXIMUM PRESSURE	69 bar (1000 psig) with wafer mount See Table 50 for flange mount.
FLUID TEMPERATURE	-20° to 232 °C std./to 260 °C opt. (-4° to 450 °F std./to 500 °F opt).
LOW FLOW CUT-OFF	Adjustable: Set @ min. per Tables 45 to 49.
HIGH FLOW CUT-OFF	Adjustable: Set @ max. per Tables 45 to 49.
VOLTAGE	15 to 30 VDC standard. 115 or 230 VAC optional.
FREQUENCY	50 /60 Hz.
OUTPUTS	Two user programmable analog 4-20 mA outputs (600 Ohms or less load), two sets of user-programmable optically isolated outputs, one user programmable optically isolated flow pulse output, RS-232 or RS-485 Digital Interface with Multi-Drop Capability of up to 255 units (RS-485 option).
LINEAR RANGE	Reynolds number of >10,000.

VORTEX IN-LINE FLOW METERS

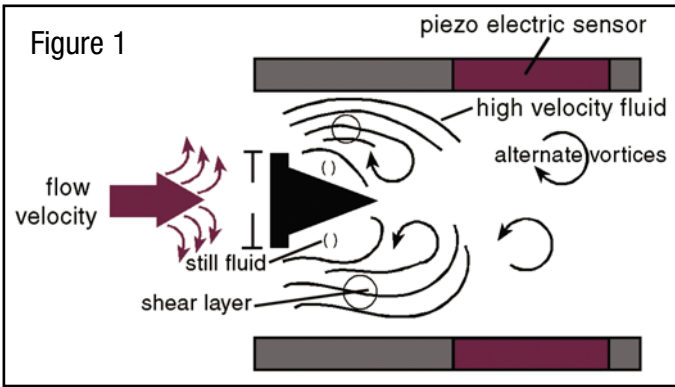

TABLE 42 - PERFORMANCE SPECIFICATIONS

FLOW ACCURACY	± 1% of rate.
FLOW REPEATABILITY	± 0.25% of rate.
FLOW TURNDOWN RATIO	See Tables 44 to 48.
RESPONSE TIME	Adjustable based on NRF and Damping settings (minimum 1000 ms).
DAMPING	Adjustable: 1 to 99 sec.
VELOCITY RANGE	Liq.: 1.32 or $\frac{10000\mu}{\bar{n}d \cdot 124}$ to 30 ft/sec. Steam & Gas: $(144/\bar{n})^{1/3}$ to 250 ft/sec. \bar{n} = density (lb/ft ³). d = pipe diameter (in). μ = viscosity (cp).
AGENCY APPROVALS*	FM and CSA Class 1 Div 2 Groups B,C,D.

TABLE 43 - PHYSICAL SPECIFICATION

**MATERIALS OF CONSTRUCTION	
SHEDDER BAR	316 SS.
ELECTRODES	316 SS encapsulated ceramic.
METERING TUBE	316 SS.
FLANGES	316L SS.
ELECTRONICS HOUSING	Epoxy coated aluminum.
CONNECTIONS AND MOUNTINGS	
MOUNTING POSITION	Vertical, horizontal, angle.
TYPICAL STRAIGHT PIPE REQUIREMENTS	Upstream: 20 x D. Downstream: 5 x D.
TEMPERATURE TAP (BY CUSTOMER)	Downstream: 3.5 x D.
PRESSURE TAP (BY CUSTOMER)	Upstream: 3.5 x D.
PROCESS CONNECTIONS	ANSI Class 150 RF, 300 RF, 600 RF, Wafer.
ELECTRICAL CONNECT	3/4" FNPT.

TABLE 44 - ELECTRONIC SPECIFICATIONS

AMBIENT TEMPERATURE	-12° to 65 °C (-15° to 149 °F).
TRANSMITTER	Microprocessor-based.
DISPLAY	Two lines, 16 alphanumeric characters each, programmable for different process variable rate and total.
FUNCTIONS	Measuring Units, Programmable Flow Alarm, Two Programmable Totalizers, Programmable Flow Rate Pulse Output, Two Programmable Optically Isolated Outputs, Two Programmable analog 4-20 mA outputs, Battery Backed Real Time Clock [RTC], Digital communication interface (RS-232 or RS-485), Programmable Diagnostic events Log and register with date and time stamp, Programmable Process Variable Data Log (total 15872 records) with date and time stamp, Calibration and Flowing Fluid parameters adjustment, Extensive Diagnostic.
OUTPUT SIGNAL	Two programmable analog 4-20 mA into 600 Ohms or less load, two programmable digital optically isolated (UCE @ 40Vdc, ICE @ 150 mA), one programmable optically isolated flow pulse output (UCE @ 60Vdc, ICE @ 50 mA).
ENCLOSURE PROTECTION	NEMA 4X.
ENCLOSURE APPROVALS	UL, CSA, FM Class I Groups B, C, D Class II Groups E, F, G KEMA/CENELEC EEx d IIB
POWER SUPPLY	15-30 VDC standard 115 or 230 VAC (optional).

* Designed to meet.
Contact Aalborg for status of the agency approval.

**The selection of materials of construction, is the responsibility of the customer. The company accepts no liability.



Flow Ranges

Minimum and maximum flow rates to achieve accuracy in gal/min, L/min. Pipe ID based on schedule 80 steel.

TABLE 45 - WATER FLOW RATES AT 60 °F												
SIZE (INCH)	3/4"		1"		1.5"		2"		3"		4"	
	min	max	min	max	min	max	min	max	min	max	min	max
gal/min	4	40.4	7	67.2	17	164.9	28	276.0	62	617.6	107	1075.3
L/min	15	152.9	25	254.3	62	624.4	104	1044.9	238	2337.9	407	4070.4

Minimum and maximum flow rates to achieve accuracy lb/hr. Pipe ID based on schedule 80 steel.

TABLE 46 - SATURATED STEAM FLOW RATES AT SELECTED PROCESS PRESSURES (English)												
SIZE (INCH)	3/4"		1"		1.5"		2"		3"		4"	
PRESSURE (psig)	min	max	min	max	min	max	min	max	min	max	min	max
10	16.4	163.8	27.2	272.4	66.9	669.3	111.8	1118.3	250.2	2501.6	435.4	4354.1
25	25.5	255.3	42.5	424.7	104.3	1043.4	174.4	1743.5	390	3900.1	678.8	6788.4
50	40.4	403.6	67.1	671.4	165	1649.5	275.6	2756.3	616.5	6165.4	1073.1	10731.4
75	54.9	549.2	91.4	913.5	224.4	2244.3	375	3750.2	838.9	8388.7	1460.1	14601.1
100	69.3	693.2	115.3	1153.1	283.3	2832.8	473.4	4733.6	1058.8	10588.3	1843	18429.8
125	83.6	836.2	139.1	1391	341.7	3417.4	571.1	5710.5	1277.4	12773.6	2223.3	22233.4
150	97.9	978.7	162.8	1628	400	3999.7	668.3	6683.4	1495	14949.9	2602.1	26021.4
200	126.3	1262.8	210.1	2100.6	516.1	5160.7	862.4	8623.5	1929	19289.7	3357.5	33575.2
250	154.7	1546.9	257.3	2573.2	632.2	6321.6	1056.3	10563.3	2362.9	23628.6	4112.8	41127.5
300	182.1	1821.1	302.9	3029.3	744.2	7442.1	1243.6	12435.7	2781.7	27817.1	4841.8	48417.8
350	211.7	2116.5	352.1	3520.7	865	8649.5	1445.3	14453.3	3233	32330	5627.3	56273
400	241.3	2413.1	401.4	4014.2	986.2	9861.8	1647.9	16478.9	3686.1	36861.2	6416	64159.9
450	271	2710.2	450.8	4508.3	1107.6	11075.8	1850.8	18507.6	4139.9	41399	7505.8	75058.2
500	300.8	3007.5	500.3	5002.9	1229.1	12290.7	2053.8	20537.6	4594	45940	7996.2	79962.2
550	330.5	3305.2	549.8	5498.1	1350.7	13507.3	2257.1	22570.6	5048.7	50487.4	8787.7	87877.4
600	360.4	3603.8	599.5	5994.9	1472.8	14727.8	2461	24609.9	5504.9	55049.2	9581.7	95817.5



Minimum and maximum flow rates to achieve accuracy in (kg/hr) Pipe ID based on schedule 80 steel.

TABLE 47 - SATURATED STEAM FLOW RATES AT SELECTED PROCESS PRESSURES (Metric)

Size (mm)	20		25		40		50		80		100	
Pressure (bara)	min	max	min	max	min	max	min	max	min	max	min	max
1	4.6	45.6	7.6	75.8	18.6	186.2	31.1	311.2	69.6	696.1	121.2	1211.6
2	8.7	87.4	14.6	145.5	35.7	357.4	59.7	597.1	133.6	1335.7	232.5	2324.9
4	16.7	167.4	27.8	278.4	68.4	683.9	114.3	1142.8	255.6	2556.3	445	4449.5
6	24.5	245.2	40.8	407.8	100.2	1001.9	167.4	1674.2	374.5	3744.9	651.8	6518.3
10	39.8	398.2	66.2	662.4	162.7	1627.3	271.9	2719.3	608.3	6082.6	1058.7	10587.3
14	55	549.9	91.5	914.7	224.7	2247.2	375.5	3755.1	840	8399.6	1462	14620.2
18	70.1	701.4	116.7	1166.7	286.6	2866.4	479	4789.7	1071.4	10713.9	1864.9	18648.5
22	84.9	849.3	141.3	1412.8	347.1	3470.8	580	5799.6	1297.3	12972.9	2258.1	22580.5
26	100.7	1007.1	167.5	1675.3	411.6	4115.7	687.7	6877.3	1538.4	15383.6	2677.6	26776.4
28	108.6	1086.2	180.7	1806.9	443.9	4439.2	741.8	7417.8	1659.3	16592.6	2888.1	28880.7
30	116.6	1165.5	193.9	1938.7	476.3	4762.9	795.9	7958.7	1780.3	17802.6	3098.7	30986.9
32	124.5	1244.7	207.1	2070.5	508.7	5086.8	850	8499.9	1901.3	19013.2	3309	33094
34	132.4	1324	220.2	2202.4	541.1	5410.8	904.1	9041.3	2022.4	20224.2	3520.2	35201.9
36	140.3	1403.3	233.4	2334.4	573.5	5735	958.3	9583	2143.6	21436	3731.1	37311.1
38	148.3	1482.7	246.7	2466.5	606	6059.5	1012.5	10125.3	2264.9	22649	3942.3	39422.5
40	156.2	1562.3	259.9	2598.8	638.5	6384.6	1066.9	10668.5	2386.4	23864.1	4153.7	41537.4

Minimum and maximum flow rates to achieve accuracy in CFPM (14.7 psia 70 °F) CFM at actual process temperature = min. or max values below *530/ (Actual Temp. (°F) + 460) Pipe ID based on schedule 80 steel. Flow Temp. 70 °F.

TABLE 48 - AIR FLOW RATES AT SELECTED PROCESS PRESSURES (English)

Size (inch)		3/4"		1"		1.5"		2"		3"		4"	
Density (lb/ft3)	Pressure (psig)	min	max	min	max	min	max	min	max	min	max	min	max
0.076	0	5	45.0	8	74.9	18	183.8	31	307.5	69	688.1	120	1197.9
0.103	5	6	60.3	10	100.3	25	246.3	41	412.1	92	922.1	160	1605.3
0.128	10	8	75.6	13	125.8	31	308.8	52	516.7	116	1156.1	201	2012.8
0.180	20	11	106.2	18	176.7	43	433.8	73	725.9	162	1624.2	283	2827.7
0.232	30	14	136.8	23	227.6	56	558.8	94	935.1	209	2092.2	364	3642.6
0.284	40	17	167.4	28	278.5	68	683.8	114	1144.2	256	2560.3	446	4457.5
0.336	50	20	198.1	33	329.4	81	808.8	135	1353.4	303	3028.4	527	5272.4
0.388	60	23	228.7	38	380.4	93	933.8	156	1562.6	350	3496.4	609	6087.3
0.440	70	26	259.3	43	431.3	106	1058.8	177	1771.8	396	3964.5	690	6902.2
0.493	80	29	289.9	48	482.2	118	1183.8	198	1981.0	443	4432.5	718	7717.1
0.545	90	32	320.5	53	533.1	131	1308.8	219	2190.2	490	4900.6	853	8532.0
0.596	100	35	351.1	58	584.0	143	1433.8	240	2399.3	537	5368.7	935	9346.9
0.649	110	38	381.7	64	635.0	156	1558.8	261	2608.5	584	5836.7	1016	10161.8
0.700	120	41	412.3	69	685.9	168	1683.8	282	2817.7	630	6304.8	1098	10976.7
0.752	130	44	443.0	74	736.8	181	1808.8	303	3026.9	677	6772.8	1179	11791.6
0.804	140	47	473.6	79	787.7	193	1933.8	324	3236.1	724	7240.9	1261	12606.5
0.856	150	50	504.2	84	838.6	206	2058.8	344	3445.3	771	7709.0	1342	13421.4
1.116	200	66	657.2	109	1093.2	268	2683.8	449	4491.2	1005	10049.3	1750	17495.9
1.636	300	96	963.4	160	1602.4	393	3933.8	658	6583.0	1473	14729.9	2564	25644.8



Minimum and maximum flow rates to achieve accuracy in M³/min (°C, 1.013 bar). M³/min at actual process temperature = minimum or maximum values below x 273 (actual temp (°C) + 273). Pipe ID based on schedule 80 steel. Flow Temp 0 °C.

TABLE 49 - AIR FLOW RATES AT SELECTED PROCESS PRESSURES (Metric)

Size (mm)		20		25		40		50		80		100	
Density (kg/m ³)	Pressure (barg)	min	max	min	max	min	max	min	max	min	max	min	max
1.293	0	0.1	1.28	0.2	2.10	0.5	5.21	0.9	8.69	1.9	19.48	3.4	33.92
1.93	0.5	0.2	1.91	0.3	3.14	0.8	7.78	1.3	12.97	2.9	29.08	5.1	50.66
2.568	1	0.3	2.54	0.4	4.18	1.0	10.35	1.7	17.26	3.9	38.69	6.8	67.39
3.844	2	0.4	3.81	0.6	6.25	1.5	15.49	2.6	25.82	5.8	57.90	10.1	100.85
5.12	3	0.5	5.07	0.8	8.33	2.0	20.64	3.4	34.39	7.7	77.11	13.4	134.31
6.39	4	0.6	6.33	1.0	10.40	2.6	25.78	4.3	42.96	9.6	96.32	16.8	167.77
7.67	5	0.8	7.59	1.2	12.48	3.1	30.92	5.2	51.53	11.6	115.54	20.1	201.24
8.95	6	0.9	8.86	1.5	14.55	3.6	36.06	6.0	60.10	13.5	134.75	23.5	234.70
10.22	7	1.0	10.12	1.7	16.62	4.1	41.20	6.9	68.67	15.4	153.96	26.8	268.16
11.5	8	1.1	11.38	1.9	18.70	4.6	46.34	7.7	77.24	17.3	173.17	30.2	301.63
12.77	9	1.2	12.64	2.1	20.77	5.1	51.48	8.6	85.80	19.2	192.38	33.5	335.09
14.05	10	1.4	13.91	2.3	22.85	5.7	56.62	9.4	94.37	21.2	211.59	36.9	368.55
15.32	11	1.5	15.17	2.5	24.92	6.2	61.76	10.3	102.94	23.0	230.81	40.2	402.01
16.6	12	1.6	16.43	2.7	27.00	6.7	66.91	11.1	111.51	25.0	250.02	43.5	435.48
17.88	13	1.8	17.70	2.9	29.07	7.2	72.05	12.0	120.08	26.9	269.23	46.9	468.94
19.15	14	1.9	18.96	3.1	31.15	7.7	77.19	12.9	128.65	28.8	288.44	50.2	502.40
22.98	17	2.2	22.75	3.7	37.37	9.3	92.61	15.4	154.35	34.6	346.08	60.3	602.79
26.81	20	2.6	26.54	4.4	43.59	10.1	108.04	18.0	180.06	40.4	403.71	70.3	703.18

ANSI Flange Pressure - Temperature Ratings.
Maximum Pressure in psig.

TABLE 50 - FLOW METER PRESSURE RATING

MATERIAL	TEMP. °F				
	-100 to 100	200	300	400	500
316L SS 150# RF	230	195	175	160	145
316L SS 300# RF	600	505	455	415	380
316L SS 600# RF	1000	1000	910	825	765

Ambient Temperature Range for Electronics

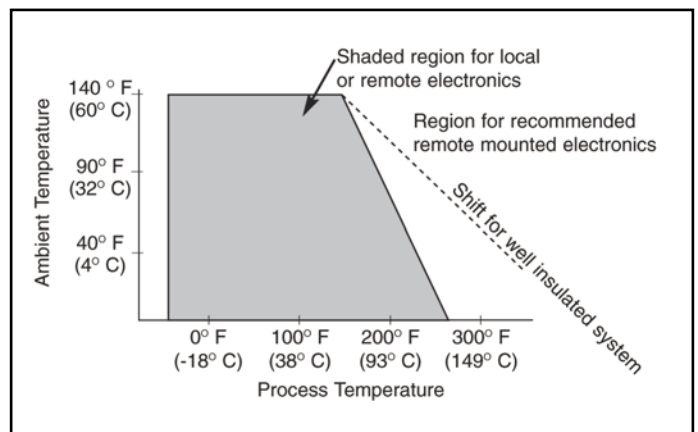



Flange Mounting

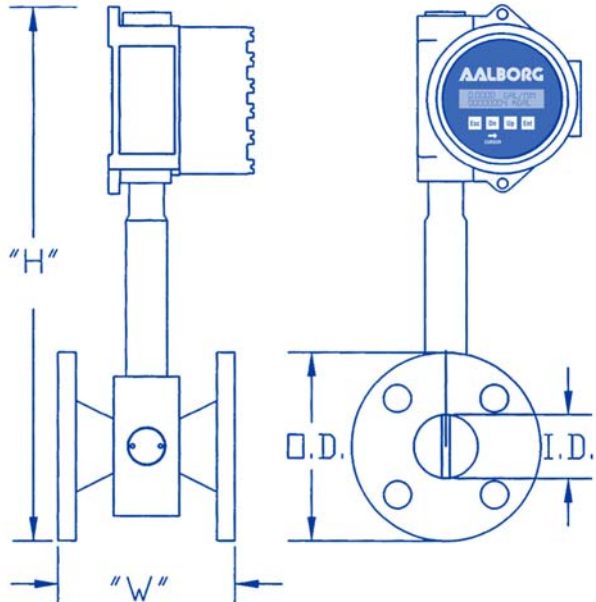

TABLE 51

Meter Size	Flange Rating	Bolt diameter	Bolts	I.D.	O.D.	"W"	"H"
in.	psi	in.	no.	in.	in.	in.	in.
3/4	150	1/2	4	0.742	3.875	5.88	9.75
	300	5/8	4		4.625	6.25	10.125
	600	5/8	4		4.625	6.25	10.125
	900	7/8	4		5.125	7.25	10.375
1	150	1/2	4	0.957	4.25	6.13	9.95
	300	5/8	4		4.875	6.63	10.27
	600	5/8	4		4.875	6.63	10.27
	900	1	4		5.875	7.5	10.76
1.5	150	1/2	4	1.50	5.00	6.63	10.35
	300	3/4	4		6.125	7.13	10.91
	600	3/7	4		6.125	7.25	10.91
	900	1-1/8	4		7.00	8.25	11.35
2	150	5/8	4	1.937	6.00	6.75	10.875
	300	5/8	4		6.50	7.25	11.125
	600	5/8	4		6.50	7.50	11.125
	900	1	4		8.50	9.75	12.125
3	150	5/8	4	2.900	7.50	7.25	11.60
	300	3/4	8		8.25	8.00	11.98
	600	3/4	8		8.25	8.25	11.98
	900	1	8		9.50	9.75	12.60
4	150	5/8	4	3.826	9.00	8.25	12.37
	300	3/4	8		10.00	9.00	12.87
	600	7/8	8		10.75	10.25	13.25
	900	1-1/4	8		11.50	11.285	13.62

Wafer Mounting

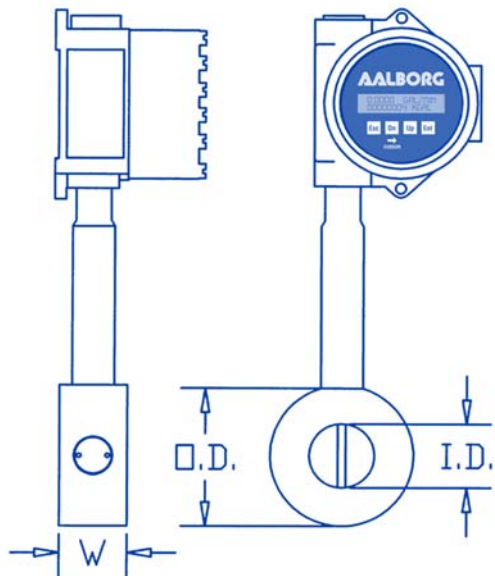

TABLE 52

Meter Size	Flange Rating	Bolt diameter	Bolts	I.D.	O.D.	"W"	"H"
in.	psi	in.	no.	in.	in.	in.	in.
3/4	150	1/2	4	0.742	2.370	2	9.00
	300	5/8	4				
	600	5/8	4				
1	150	1/2	4	0.957	2.740	2	9.20
	300	5/8	4				
	600	5/8	4				
1.5	150	1/2	4	1.500	3.500	2	9.60
	300	3/4	4				
	600	3/4	4				
2	150	5/8	4	1.937	4.250	2	10.00
	300	5/8	8				
	600	5/8	8				
3	150	5/8	4	2.900	5.497	2	10.60
	300	3/4	8				
	600	3/4	8				
4	150	5/8	8	3.826	6.997	2.5	11.37
	300	3/4	8				
	600	7/8	8				



MODEL	
VX	
STYLE	
U	Wafer - SCH 40
W	Wafer - SCH 80
E	Flange - SCH 40
F	Flange - SCH 80

SIZE: WAFER or FLANGE	
07	3/4" (20mm)
10	1.0" (25mm)
15	1.5" (40mm)
20	2.0" (50mm)
30	3.0" (80mm)
40	4.0" (100mm)

FLUID TYPE	
G	Gas
L	Liquid
S	Steam

MAX TEMP.	
4	450 °F

MATERIAL	
6	316 SS

MOUNTING CONNECTION	
A	Wafer. Using Customer Flanges
B	Flange Mounting
F	Other

FLANGE RATING†	
A	150# ANSI RF (Alignment Rings Not Required for Wafer Style)
B	300# ANSI RF (Wafer Style Includes Alignment Rings)
C	600# ANSI RF (Wafer Style Includes Alignment Rings)
D	OTHER
N	NONE

DISPLAY	
L2	Local with RS232
R2	Remote with RS232
L4	Local with RS485
R4	Remote with RS425

POWER	
04	24VDC
12	120VAC
22	220VAC

To allow us to confirm selection please return completed application data sheet found on Aalborg's web site at www.aalborg.com.

1. Select style (wafer or flange).
2. Select meter size to match internal pipe diameter
3. Confirm minimum and maximum flow ranges to maintain stated accuracy from liquid, steam, or air from Tables 45 to 48 are within your requirements.
4. For other gas applications consult factory.
5. Select fluid type.
6. Select maximum temperature capability.
7. Select desired **Material of Construction.
8. Select mounting connection.
9. Confirm maximum pressure capability of flange/meter rating with process conditions and select flange rating from Table 51
10. Confirm suitability of standard local mounted electronics.
11. Select desired transmitter power.
12. Provide: Fluid, Fluid Viscosity, Minimum & Maximum Operating Pressure, Minimum & Maximum Operating Temperature, Density/Specific Gravity or Specific Volume.
13. Provide minimum and maximum flow range.

Options: Remote mount electronics up to 100 ft. (30.5 m).

† = Wafer and Flange Style for Alignment Ring Selection.

** = The selection of materials of construction, is the responsibility of the customer. The company accepts no liability.

VX W 10 L 4 6 A B L2 22

EXAMPLE: VXW-10L-44AB-L222

SPECIFY: FLUID NAME or MEASURING DENSITY, FLOW RATE, TEMPERATURE and PRESSURE (STEAM, GASES).

Vortex meter, Wafer style, 10" diameter size, Liquid at maximum 450 °F, 316 stainless steel, Customer flanges, Flange 300# ANSI RF, Local display with RS232, 220V power.

www.aalborg.com - e-mail info@aalborg.com - ☎ 845.770.3000 - fax 845.770.3010 - Toll Free in U.S.A. and Canada 1.800.866.3837



Design Features

- Temperature, pressure, density, volumetric and mass flow measurements.
- No moving parts to wear or fail.
- Electronics can be remotely mounted up to 30.5 m (100 ft).
- No fluid to sensor contact.
- No holes to clog.
- High flow turndown ratio up to 10:1.
- Dual signal processing technology improves accuracy at low flows.
- Accuracy of $\pm 1\%$ of rate.
- Noise cancellation technology.
- Built in platinum RTD and solid state pressure sensor.
- On board computer calculates density, volumetric and mass flow.
- Aalborg's proprietary DSP algorithm accurately filters vortex frequency.
- Extensive Diagnostics log with date and time register.
- Password protected data entry.
- Volumetric and mass flow information simultaneously displayed.
- Selectable engineering units.
- Two programmable totalizers.
- Digital communication interface: RS-232 or RS-485.

Principles of Operation

Vortices are created when a fluid passes around a bluff body as shown in Figure 1. Vortices are alternately shed on each side of the body, 180 degrees out of phase to each other, resulting in an oscillating pressure gradient. As flow increases the frequency of vortices increases in proportion to the increased flow thereby creating a linear relationship.

General Description

Constructed of type 316 stainless steel, wafers may be installed in-line by customer provided or built-in flanges. Key pad or communication interface functionalities include measuring units, programmable flow alarm, two programmable totalizers, programmable flow rate pulse output, two programmable optically isolated outputs, battery backed real time clock (RTC), digital communication interface (RS-232 or RS-485), programmable diagnostic events log and register with date and time stamp, programmable process variable log with date stamp, calibration and flowing fluid parameters adjustment, extensive diagnostics.

Our exclusive dual signal processing technology independently measures each vortex on either side of the bluff body and filters out non-flow noise. This results in less noise and higher accuracy throughout the flow range. Aalborg's proprietary DSP algorithm accurately filters vortex frequency, improving the quality of flow measurements.

Local 2x16 LCD readout provides flow rate and total flow volume reading in selectable engineering units, diagnostic events indication and feature a password protected access to the process parameters to ensure against tampering or resetting.



Vortex In-line Flow Meter Shown with Wafer Mounting

Vortex In-line Flow Meter Shown with Flange Mounting

TABLE 53 - FUNCTIONAL SPECIFICATIONS	
FLUID TYPES	Steam, Gas, Liquid.
MAXIMUM PRESSURE	69 bar (1000 psig) with wafer mount See Table 62 for flange mount.
FLUID TEMPERATURE	-20° to 232 °C std./to 260 °C opt. (-4° to 450 °F std./to 500 °F opt).
LOW FLOW CUT-OFF	Adjustable: Set @ min. per Tables 57 to 61.
HIGH FLOW CUT-OFF	Adjustable: Set @ max. per Tables 57 to 61.
VOLTAGE	15 to 30 VDC standard. 115 or 230 VAC optional.
FREQUENCY	50 /60 Hz.
OUTPUTS	Two user programmable analog 4-20 mA outputs (600 Ohms or less load). Each can be assigned to one of the following process variables: volumetric flow, mass flow, temperature or pressure. Two sets of user programmable digital optically isolated outputs to actuate user supplied equipment when various diagnostic or system events occurs. One user programmable optically isolated flow pulse output, RS-232 or RS-485 Digital Interface with Multi-Drop Capability of up to 255 units (RS-485 option).
LINEAR RANGE	Reynolds number of >10,000.



TABLE 54 - PERFORMANCE SPECIFICATIONS

FLOW ACCURACY	± 1% of rate.
FLOW REPEATABILITY	± 0.25% of rate.
FLOW TURNDOWN RATIO	See Tables 57 to 61.
RESPONSE TIME	Adjustable based on NRF and Damping settings (minimum 1000 ms).
DAMPING	Adjustable: 1 to 99 sec.
VELOCITY RANGE	Liq.: $1.32 \text{ or } \frac{10000\mu}{\bar{n}d \cdot 124}$ to 30 ft/sec. Steam & Gas: $(144/\bar{n})^{1/3}$ to 250 ft/sec. \bar{n} = density (lb/ft ³). d= pipe diameter (in). μ = viscosity (cp).
AGENCY APPROVALS*	FM and CSA Class 1 Div 2 Groups B,C,D.
FLUID TEMPERATURE MEASUREMENT RANGE	20 to 260 °C (-4 to 500 °F).
TEMPERATURE ACCURACY (INCLUDING LINEARITY)	± 0.5 °C
FLUID PRESSURE MEASUREMENT RANGE	Can be ordered for the following options: 0-100 PSIA. 0-200 PSIA. 0-300 PSIA. 0- 500 PSIA. 0-750 PSIA. 0-1000 PSIA.
PRESSURE ACCURACY (INCLUDING LINEARITY)	± 0.5% of full scale.
FLUID PROOF PRESSURE	3 X F.S.
FLUID BURST PRESSURE	10 X F.S.

TABLE 55 - PHYSICAL SPECIFICATION

****MATERIALS OF CONSTRUCTION**

SHEDDER BAR	316 SS.
ELECTRODES	316 SS encapsulated ceramic.
METERING TUBE	316 SS.
FLANGES	316 SS.
ELECTRONICS HOUSING	Epoxy coated aluminum.

CONNECTIONS AND MOUNTINGS

MOUNTING POSITION	Vertical, horizontal, angle.
TYPICAL STRAIGHT PIPE REQUIREMENTS	Upstream: 20 x D. Downstream: 5 x D.
TEMPERATURE TAP (BY CUSTOMER)	Downstream: 3.5 x D.
PRESSURE TAP (BY CUSTOMER)	Upstream: 3.5 x D.
PROCESS CONNECTIONS	ANSI Class 150 RF, 300 RF, 600 RF, Wafer.
ELECTRICAL CONNECT	3/4" FNPT.

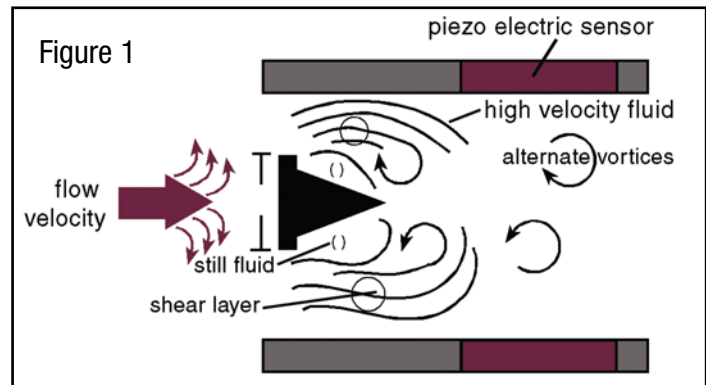

TABLE 56 - ELECTRONIC SPECIFICATIONS

AMBIENT TEMPERATURE	-12° to 65 °C (-15° to 149 °F).
TRANSMITTER	Microprocessor-based.
DISPLAY	Two lines, 16 alphanumeric characters each, programmable for different process variable rate and total.
FUNCTIONS	Measuring Units, Programmable Flow, Temperature and Pressure Alarms, Two Programmable Totalizers, Programmable Flow Rate Pulse Output, Two Programmable Optically Isolated Outputs, Two Programmable analog 4-20 mA outputs, Battery Backed Real Time Clock [RTC], Digital communication interface (RS-232 or RS-485), Programmable Diagnostic events Log and register with date and time stamp, Programmable Process Variable Data Log (total 15872 records) with date and time stamp, Calibration and Flowing Fluid parameters adjustment, Extensive Diagnostic.
OUTPUT SIGNAL	Two programmable analog 4-20 mA into 600 Ohms or less load, two programmable digital optically isolated (UCE @ 40Vdc, ICE @ 150 mA), one programmable optically isolated flow pulse output (UCE @ 60Vdc, ICE @ 50 mA).
ENCLOSURE PROTECTION	NEMA 4X.
ENCLOSURE APPROVALS	UL, CSA, FM Class I Groups B, C, D Class II Groups E, F, G KEMA/CENELEC EEx d IIB
POWER SUPPLY	15-30 VDC standard 115 or 230 VAC (optional).

* Designed to meet.
Contact Aalborg for status of the agency approval.

**The selection of materials of construction, is the responsibility of the customer. The company accepts no liability.



Flow Ranges

Minimum and maximum flow rates to achieve accuracy in gal/min, L/min. Pipe ID based on schedule 80 steel.

TABLE 57 - WATER FLOW RATES AT 60 °F

SIZE (INCH)	3/4"		1"		1.5"		2"		3"		4"	
	min	max	min	max	min	max	min	max	min	max	min	max
gal/min	4	40.4	7	67.2	17	164.9	28	276.0	62	617.6	107	1075.3
L/min	15	152.9	25	254.3	62	624.4	104	1044.9	238	2337.9	407	4070.4

Minimum and maximum flow rates to achieve accuracy lb/hr. Pipe ID based on schedule 80 steel.

TABLE 58- SATURATED STEAM FLOW RATES AT SELECTED PROCESS PRESSURES (English)

SIZE (INCH)	3/4"		1"		1.5"		2"		3"		4"	
PRESSURE (psig)	min	max	min	max	min	max	min	max	min	max	min	max
10	16.4	163.8	27.2	272.4	66.9	669.3	111.8	1118.3	250.2	2501.6	435.4	4354.1
25	25.5	255.3	42.5	424.7	104.3	1043.4	174.4	1743.5	390	3900.1	678.8	6788.4
50	40.4	403.6	67.1	671.4	165	1649.5	275.6	2756.3	616.5	6165.4	1073.1	10731.4
75	54.9	549.2	91.4	913.5	224.4	2244.3	375	3750.2	838.9	8388.7	1460.1	14601.1
100	69.3	693.2	115.3	1153.1	283.3	2832.8	473.4	4733.6	1058.8	10588.3	1843	18429.8
125	83.6	836.2	139.1	1391	341.7	3417.4	571.1	5710.5	1277.4	12773.6	2223.3	22233.4
150	97.9	978.7	162.8	1628	400	3999.7	668.3	6683.4	1495	14949.9	2602.1	26021.4
200	126.3	1262.8	210.1	2100.6	516.1	5160.7	862.4	8623.5	1929	19289.7	3357.5	33575.2
250	154.7	1546.9	257.3	2573.2	632.2	6321.6	1056.3	10563.3	2362.9	23628.6	4112.8	41127.5
300	182.1	1821.1	302.9	3029.3	744.2	7442.1	1243.6	12435.7	2781.7	27817.1	4841.8	48417.8
350	211.7	2116.5	352.1	3520.7	865	8649.5	1445.3	14453.3	3233	32330	5627.3	56273
400	241.3	2413.1	401.4	4014.2	986.2	9861.8	1647.9	16478.9	3686.1	36861.2	6416	64159.9
450	271	2710.2	450.8	4508.3	1107.6	11075.8	1850.8	18507.6	4139.9	41399	7505.8	75058.2
500	300.8	3007.5	500.3	5002.9	1229.1	12290.7	2053.8	20537.6	4594	45940	7996.2	79962.2
550	330.5	3305.2	549.8	5498.1	1350.7	13507.3	2257.1	22570.6	5048.7	50487.4	8787.7	87877.4
600	360.4	3603.8	599.5	5994.9	1472.8	14727.8	2461	24609.9	5504.9	55049.2	9581.7	95817.5



VORTEX MULTI-PARAMETER IN-LINE FLOW METERS

Minimum and maximum flow rates to achieve accuracy in (kg/hr) Pipe ID based on schedule 80 steel.

TABLE 59 - SATURATED STEAM FLOW RATES AT SELECTED PROCESS PRESSURES (Metric)

Size (mm)	20		25		40		50		80		100	
Pressure (bara)	min	max	min	max	min	max	min	max	min	max	min	max
1	4.6	45.6	7.6	75.8	18.6	186.2	31.1	311.2	69.6	696.1	121.2	1211.6
2	8.7	87.4	14.6	145.5	35.7	357.4	59.7	597.1	133.6	1335.7	232.5	2324.9
4	16.7	167.4	27.8	278.4	68.4	683.9	114.3	1142.8	255.6	2556.3	445	4449.5
6	24.5	245.2	40.8	407.8	100.2	1001.9	167.4	1674.2	374.5	3744.9	651.8	6518.3
10	39.8	398.2	66.2	662.4	162.7	1627.3	271.9	2719.3	608.3	6082.6	1058.7	10587.3
14	55	549.9	91.5	914.7	224.7	2247.2	375.5	3755.1	840	8399.6	1462	14620.2
18	70.1	701.4	116.7	1166.7	286.6	2866.4	479	4789.7	1071.4	10713.9	1864.9	18648.5
22	84.9	849.3	141.3	1412.8	347.1	3470.8	580	5799.6	1297.3	12972.9	2258.1	22580.5
26	100.7	1007.1	167.5	1675.3	411.6	4115.7	687.7	6877.3	1538.4	15383.6	2677.6	26776.4
28	108.6	1086.2	180.7	1806.9	443.9	4439.2	741.8	7417.8	1659.3	16592.6	2888.1	28880.7
30	116.6	1165.5	193.9	1938.7	476.3	4762.9	795.9	7958.7	1780.3	17802.6	3098.7	30986.9
32	124.5	1244.7	207.1	2070.5	508.7	5086.8	850	8499.9	1901.3	19013.2	3309	33094
34	132.4	1324	220.2	2202.4	541.1	5410.8	904.1	9041.3	2022.4	20224.2	3520.2	35201.9
36	140.3	1403.3	233.4	2334.4	573.5	5735	958.3	9583	2143.6	21436	3731.1	37311.1
38	148.3	1482.7	246.7	2466.5	606	6059.5	1012.5	10125.3	2264.9	22649	3942.3	39422.5
40	156.2	1562.3	259.9	2598.8	638.5	6384.6	1066.9	10476.7	2386.4	23864.1	4153.7	41537.4

Minimum and maximum flow rates to achieve accuracy in CFPM (14.7 psia 70 °F) CFM at actual process temperature = min. or max values below *530/ (Actual Temp. (°F) + 460) Pipe ID based on schedule 80 steel. Flow Temp. 70 °F.

TABLE 60 - AIR FLOW RATES AT SELECTED PROCESS PRESSURES (English)

Size (inch)		3/4"		1"		1.5"		2"		3"		4"	
Density (lb/ft3)	Pressure (psig)	min	max	min	max	min	max	min	max	min	max	min	max
0.076	0	5	45.0	8	74.9	18	183.8	31	307.5	69	688.1	120	1197.9
0.103	5	6	60.3	10	100.3	25	246.3	41	412.1	92	922.1	160	1605.3
0.128	10	8	75.6	13	125.8	31	308.8	52	516.7	116	1156.1	201	2012.8
0.180	20	11	106.2	18	176.7	43	433.8	73	725.9	162	1624.2	283	2827.7
0.232	30	14	136.8	23	227.6	56	558.8	94	935.1	209	2092.2	364	3642.6
0.284	40	17	167.4	28	278.5	68	683.8	114	1144.2	256	2560.3	446	4457.5
0.336	50	20	198.1	33	329.4	81	808.8	135	1353.4	303	3028.4	527	5272.4
0.388	60	23	228.7	38	380.4	93	933.8	156	1562.6	350	3496.4	609	6087.3
0.440	70	26	259.3	43	431.3	106	1058.8	177	1771.8	396	3964.5	690	6902.2
0.493	80	29	289.9	48	482.2	118	1183.8	198	1981.0	443	4432.5	718	7717.1
0.545	90	32	320.5	53	533.1	131	1308.8	219	2190.2	490	4900.6	853	8532.0
0.596	100	35	351.1	58	584.0	143	1433.8	240	2399.3	537	5368.7	935	9346.9
0.649	110	38	381.7	64	635.0	156	1558.8	261	2608.5	584	5836.7	1016	10161.8
0.700	120	41	412.3	69	685.9	168	1683.8	282	2817.7	630	6304.8	1098	10976.7
0.752	130	44	443.0	74	736.8	181	1808.8	303	3026.9	677	6772.8	1179	11791.6
0.804	140	47	473.6	79	787.7	193	1933.8	324	3236.1	724	7240.9	1261	12606.5
0.856	150	50	504.2	84	838.6	206	2058.8	344	3445.3	771	7709.0	1342	13421.4
1.116	200	66	657.2	109	1093.2	268	2683.8	449	4491.2	1005	10049.3	1750	17495.9
1.636	300	96	963.4	160	1602.4	393	3933.8	658	6583.0	1473	14729.9	2564	25644.8



VORTEX MULTI-PARAMETER IN-LINE FLOW METERS

Minimum and maximum flow rates to achieve accuracy in M³/min (°C, 1.013 bar). M³/min at actual process temperature = minimum or maximum values below x 273 (actual temp (°C) + 273). Pipe ID based on schedule 80 steel. Flow Temp 0 °C.

TABLE 61 - AIR FLOW RATES AT SELECTED PROCESS PRESSURES (Metric)

Size (mm)		20		25		40		50		80		100	
Density (kg/m ³)	Pressure (barg)	min	max	min	max	min	max	min	max	min	max	min	max
1.293	0	0.1	1.28	0.2	2.10	0.5	5.21	0.9	8.69	1.9	19.48	3.4	33.92
1.93	0.5	0.2	1.91	0.3	3.14	0.8	7.78	1.3	12.97	2.9	29.08	5.1	50.66
2.568	1	0.3	2.54	0.4	4.18	1.0	10.35	1.7	17.26	3.9	38.69	6.8	67.39
3.844	2	0.4	3.81	0.6	6.25	1.5	15.49	2.6	25.82	5.8	57.90	10.1	100.85
5.12	3	0.5	5.07	0.8	8.33	2.0	20.64	3.4	34.39	7.7	77.11	13.4	134.31
6.39	4	0.6	6.33	1.0	10.40	2.6	25.78	4.3	42.96	9.6	96.32	16.8	167.77
7.67	5	0.8	7.59	1.2	12.48	3.1	30.92	5.2	51.53	11.6	115.54	20.1	201.24
8.95	6	0.9	8.86	1.5	14.55	3.6	36.06	6.0	60.10	13.5	134.75	23.5	234.70
10.22	7	1.0	10.12	1.7	16.62	4.1	41.20	6.9	68.67	15.4	153.96	26.8	268.16
11.5	8	1.1	11.38	1.9	18.70	4.6	46.34	7.7	77.24	17.3	173.17	30.2	301.63
12.77	9	1.2	12.64	2.1	20.77	5.1	51.48	8.6	85.80	19.2	192.38	33.5	335.09
14.05	10	1.4	13.91	2.3	22.85	5.7	56.62	9.4	94.37	21.2	211.59	36.9	368.55
15.32	11	1.5	15.17	2.5	24.92	6.2	61.76	10.3	102.94	23.0	230.81	40.2	402.01
16.6	12	1.6	16.43	2.7	27.00	6.7	66.91	11.1	111.51	25.0	250.02	43.5	435.48
17.88	13	1.8	17.70	2.9	29.07	7.2	72.05	12.0	120.08	26.9	269.23	46.9	468.94
19.15	14	1.9	18.96	3.1	31.15	7.7	77.19	12.9	128.65	28.8	288.44	50.2	502.40
22.98	17	2.2	22.75	3.7	37.37	9.3	92.61	15.4	154.35	34.6	346.08	60.3	602.79
26.81	20	2.6	26.54	4.4	43.59	10.1	108.04	18.0	180.06	40.4	403.71	70.3	703.18

ANSI Flange Pressure - Temperature Ratings.
Maximum Pressure in psig.

TABLE 62 - FLOW METER PRESSURE RATING

MATERIAL	TEMP. °F				
	-100 to 100	200	300	400	500
316L SS 150# RF	230	195	175	160	145
316L SS 300# RF	600	505	455	415	380
316L SS 600# RF	1000	1000	910	825	765

Ambient Temperature Range for Electronics

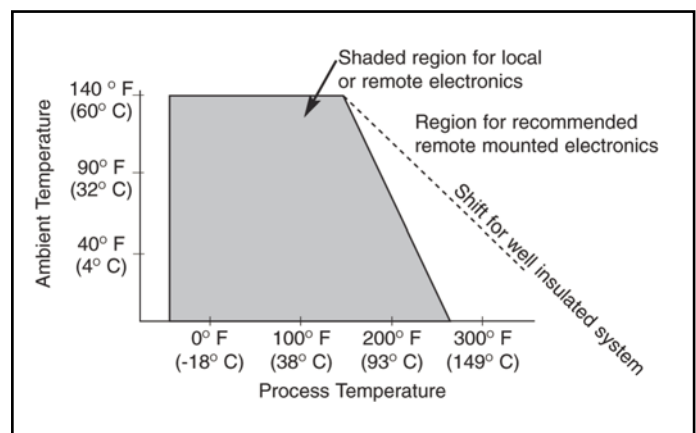

Flange Mounting

TABLE 63

Meter Size	Flange Rating	Bolt diameter	Bolts	I.D.	O.D.	"W"	"H"
in.	psi	in.	no.	in.	in.	in.	in.
3/4	150	1/2	4	0.742	3.875	FOR DIMENSIONS CONTACT AALBORG CUSTOMER SERVICE DEPARTMENT	9.75
	300	5/8	4		4.625		10.125
	600	5/8	4		4.625		10.125
	900	7/8	4		5.125		10.375
1	150	1/2	4	0.957	4.25		9.95
	300	5/8	4		4.875		10.27
	600	5/8	4		4.875		10.27
	900	1	4		5.875		10.76
1.5	150	1/2	4	1.50	5.00		10.35
	300	3/4	4		6.125		10.91
	600	3/7	4		6.125		10.91
	900	1-1/8	4		7.00		11.35
2	150	5/8	4	1.937	6.00	10.875	
	300	5/8	4		6.50	11.125	
	600	5/8	4		6.50	11.125	
	900	1	4		8.50	12.125	
3	150	5/8	4	2.900	7.50	11.60	
	300	3/4	8		8.25	11.98	
	600	3/4	8		8.25	11.98	
	900	1	8		9.50	12.60	
4	150	5/8	4	3.826	9.00	12.37	
	300	3/4	8		10.00	12.87	
	600	7/8	8		10.75	13.25	
	900	1-1/4	8		11.50	13.62	

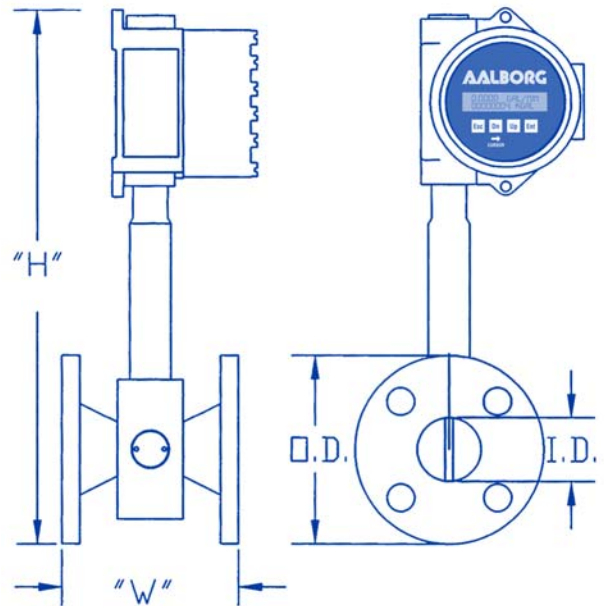

Wafer Mounting

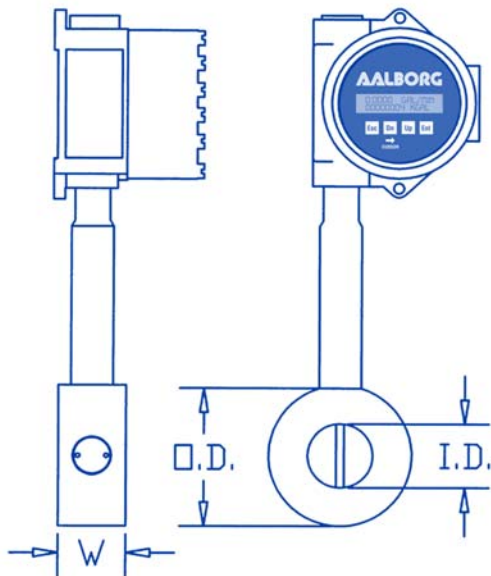

TABLE 64

Meter Size	Flange Rating	Bolt diameter	Bolts	I.D.	O.D.	"W"	"H"
in.	psi	in.	no.	in.	in.	in.	in.
3/4	150	1/2	4	0.742	2.370	FOR DIMENSIONS CONTACT AALBORG CUSTOMER SERVICE DEPARTMENT	9.00
	300	5/8	4				
	600	5/8	4				
1	150	1/2	4	0.957	2.740		9.20
	300	5/8	4				
	600	5/8	4				
1.5	150	1/2	4	1.500	3.500		9.60
	300	3/4	4				
	600	3/4	4				
2	150	5/8	4	1.937	4.250		10.00
	300	5/8	8				
	600	5/8	8				
3	150	5/8	4	2.900	5.497	10.60	
	300	3/4	8				
	600	3/4	8				
4	150	5/8	8	3.826	6.997	11.37	
	300	3/4	8				
	600	7/8	8				

ORDERING INFORMATION VORTEX MULTI-PARAMETER IN-LINE FLOW METERS



MODEL	
VX	
STYLE	
S	Wafer - SCH 40 Pressure, Temperature
T	Wafer - SCH 80 Pressure, Temperature
C	Flange - SCH 40 Pressure, Temperature
D	Flange - SCH 80 Pressure, Temperature
SIZE: WAFER or FLANGE	
07	3/4" (20mm)
10	1.0" (25mm)
15	1.5" (40mm)
20	2.0" (50mm)
30	3.0" (80mm)
40	4.0" (100mm)
FLUID TYPE	
G	Gas
L	Liquid
S	Steam
MAX TEMP. / PRESSURE	
A	450 °F / 100 PSIA
B	450 °F / 200 PSIA
C	450 °F / 300 PSIA
D	450 °F / 500 PSIA
E	450 °F / 750 PSIA
F	450 °F / 1000 PSIA
G	500 °F / 100 PSIA
H	500 °F / 200 PSIA
J	500 °F / 300 PSIA
K	500 °F / 500 PSIA
L	500 °F / 750 PSIA
M	500 °F / 1000 PSIA
MATERIAL	
6	316 SS
MOUNTING CONNECTION	
A	Wafer. Using Customer Flanges.
B	Flange Mounting.
F	Other.
FLANGE RATING †	
A	150# ANSI RF (Alignment Rings Not Required for Wafer Style)
B	300# ANSI RF (Wafer Style Includes Alignment Rings)
C	600# ANSI RF (Wafer Style Includes Alignment Rings)
D	OTHER
N	NONE
DISPLAY	
L2	Local with RS232
L4	Local with RS485
POWER	
04	24VDC
12	120VAC
22	220VAC

To allow us to confirm selection please return completed application data sheet found on Aalborg's web site at www.aalborg.com.

1. Select style (wafer or flange).
2. Select meter size to match internal pipe diameter
3. Confirm minimum and maximum flow ranges to maintain stated accuracy from liquid, steam, or air from Tables 57 to 61 are within your requirements.
4. For other gas applications consult factory.
5. Select fluid type.
6. Select maximum temperature capability.
7. Select desired **Material of Construction.
8. Select mounting connection.
9. Confirm maximum pressure capability of flange/meter rating with process conditions and select flange rating from Table 63.
10. Confirm suitability of standard local mounted electronics.
11. Select desired transmitter power.
12. Provide: Fluid, Fluid Viscosity, Minimum & Maximum Operating Pressure, Minimum & Maximum Operating Temperature, Density/Specific Gravity or Specific Volume.
13. Provide minimum and maximum flow range.

† = Flange and Wafer Style for Alignment Ring Selection.
 ** = The selection of materials of construction, is the responsibility of the customer. The company accepts no liability.

VX	D	10	L	F	6	A	B	L2	22
----	---	----	---	---	---	---	---	----	----

EXAMPLE: VXD-10L-46AB-L222

SPECIFY: FLUID NAME or MEASURING DENSITY, FLOW RATE, TEMPERATURE and PRESSURE (STEAM, GASES).
 Vortex meter, Flange style, 1.0" diameter size, Liquid at maximum 450 °F, 1000 PSIA, 316 stainless steel, Customer flanges, Flange 300# ANSI RF, Local display with RS232, 220V power.

www.aalborg.com - e-mail info@aalborg.com - ☎ 845.770.3000 - fax 845.770.3010 - Toll Free in U.S.A. and Canada 1.800.866.3837

BULLETIN EM201412 VX

Design Features

- Wide range of available insertion inside diameter applications.
- Installation by porting into piping without need to lengthening line.
- Optional installation and servicing removal of meter without shutting off line.
- No moving parts to wear or fail
- Electronics can be remotely mounted up to 30.5 m (100 ft).
- No holes to clog.
- Aalborg's proprietary DSP algorithm accurately filters vortex frequency.
- High flow turndown ratio up to 10:1.
- Dual sensor signal processing technology improves accuracy at low flows.
- Accuracy of $\pm 1\%$ of rate.
- Noise cancellation technology.
- Extensive Diagnostics.
- Password protected data entry.
- Volumetric and mass flow information simultaneously displayed.
- Selectable engineering units.
- On board computer calculates density and mass flow.
- Two programmable totalizers.

Vortex Insertion Flow Meter Shown with Fixed Mounting



Vortex Insertion Flow Meter Shown with Retractable Mounting



Principles of Operation

Vortices are created when a fluid passes around a bluff body as shown in Figure 1. Vortices are alternately shed on each side of the body, 180 degrees out of phase to each other, resulting in an oscillating pressure gradient. As flow increases the frequency of vortices increases in proportion to the increased flow thereby creating a linear relationship.

General Description

Constructed of type 316 stainless steel, Vortex meters may be inserted into pipe conduits carrying gases, liquids or steam. Insertion applications facilitate inside diameters from 4" to 12 feet!

By porting directly into piping, conduit lines need not be lengthened. Optional isolation valve permits installation, servicing, or removal of vortex meters without having to shut gas, liquid or steam processing operations.

Key pad or communication interface is provided to access the following parameters: measuring units; programmable flow alarm; two programmable totalizers; programmable flow rate pulse output; two programmable optically isolated outputs; battery backed real time clock (RTC); digital communication interface (RS-232 or RS-485); programmable diagnostic events log and register with date/time stamp; programmable process variable log with date/time stamp; calibration and flowing fluid parameters adjustment; extensive diagnostics.

Our exclusive dual signal processing technology independently measures each vortex on either side of the bluff body and filters out non-flow noise. This results in less noise and higher accuracy throughout the flow range. Aalborg's proprietary DSP algorithm accurately filters vortex frequency, improving the quality of flow measurements.

User preset temperature and pressure information processed by an on board computer to calculate density and mass flow. Local 2x16 LCD readout provides simultaneous volumetric and mass flow readings, total flow volume reading in selectable engineering units, diagnostic events indication, and password protected - user entered parameters.

TABLE 65 - FUNCTIONAL SPECIFICATIONS

FLUID TYPES	Steam, Gas, Liquid.
MAXIMUM PRESSURE	69 bar (1000 psig) with wafer mount See Table 69 for flange mount.
FLUID TEMPERATURE	-20° to 232 °C std./to 260 °C opt. (-4° to 450 °F std./to 500 °F opt).
LOW FLOW CUT-OFF	Adjustable: Set @ min. per Tables 70 to 73.
HIGH FLOW CUT-OFF	Adjustable: Set @ max. per Tables 70 to 73.
VOLTAGE	15 to 30 VDC standard. 115 or 230 VAC optional.
FREQUENCY	50 /60 Hz.
OUTPUTS	Two user programmable analog 4-20 mA outputs (600 Ohms or less load), two sets of user-programmable optically isolated outputs, one user programmable optically isolated flow pulse output, RS-232 or RS-485 Digital Interface with Multi-Drop Capability of up to 255 units (RS-485 option).
LINEAR RANGE	Reynolds number of >10,000.

**Designed to meet.
Contact Aalborg for status of the agency approval.*

TABLE 66 - PHYSICAL SPECIFICATIONS

****MATERIALS OF CONSTRUCTION**

SHEDDER BAR	316 SS.
ELECTRODES	316 SS encapsulated ceramic.
METERING TUBE	316 SS.
FLANGES	316L SS.
ELECTRONICS HOUSING	Epoxy coated aluminum.
CONNECTIONS AND MOUNTINGS	
MOUNTING POSITION	Vertical, horizontal, angle.
TYPICAL STRAIGHT PIPE REQUIREMENTS	Upstream: 20 x D. Downstream: 5 x D.
PROCESS CONNECTIONS	MNPT, ANSI Class 150 RF, 300 RF, 600 RF, Welded Flange.
ELECTRICAL CONNECT	3/4" FNPT.

***The selection of materials of construction, is the responsibility of the customer. The company accepts no liability.*

TABLE 67 - PERFORMANCE SPECIFICATIONS

FLOW ACCURACY	± 1% of rate.
FLOW REPEATABILITY	± 0.25% of rate.
FLOW TURNDOWN RATIO	See Tables 70 to 73.
RESPONSE TIME	Adjustable based on NRF and Damping settings (minimum 1000 ms).
DAMPING	Adjustable: 1 to 99 sec.
VELOCITY RANGE	Liq.: 1.32 or $\frac{10000\mu}{\bar{n}d \cdot 124}$ to 30 ft/sec Steam & Gas: $(144/\bar{n})^{1/3}$ to 250 ft/sec \bar{n} = density (lb/ft ³) d = pipe diameter (in) μ = viscosity (cp)
AGENCY APPROVALS*	FM and CSA Class 1 Div 2 Groups B,C,D.

TABLE 68 - ELECTRONIC SPECIFICATIONS

AMBIENT TEMPERATURE	-12° to 65 °C (-15° to 149 °F).
TRANSMITTER	Microprocessor-based.
DISPLAY	Two lines, 16 alphanumeric characters each, programmable for different process variable rate and total.
FUNCTIONS	Measuring Units, Programmable Flow Alarm, Two Programmable Totalizers, Programmable Flow Rate Pulse Output, Two Programmable Optically Isolated Outputs, Two Programmable analog 4-20 mA outputs, Battery Backed Real Time Clock [RTC], Digital communication interface (RS-232 or RS-485*), Programmable Diagnostic events Log and register with date and time stamp, Programmable Process Variable Data Log (total 15872 records) with date and time stamp, Calibration and Flowing Fluid parameters adjustment, Extensive Diagnostic.
OUTPUT SIGNAL	Two programmable analog 4-20 mA into 600 Ohms or less load, two programmable digital optically isolated (UCE @ 40Vdc, ICE @ 150 mA), one programmable optically isolated flow pulse out put (UCE @ 60Vdc, ICE @ 50 mA).
ENCLOSURE PROTECTION	NEMA 4X.
ENCLOSURE APPROVALS	UL, CSA, FM Class I Groups B, C, D Class II Groups E, F, G KEMA/CENELEC EEx d IIB
POWER SUPPLY	15-30 VDC standard, 115 or 230 VAC (optional).



Ambient Temperature Range for Electronics

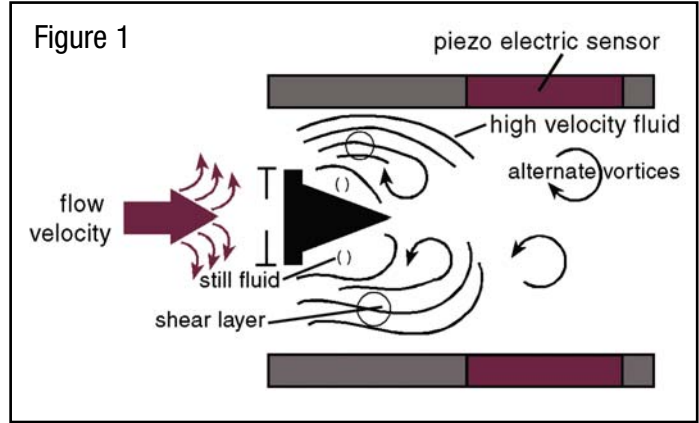
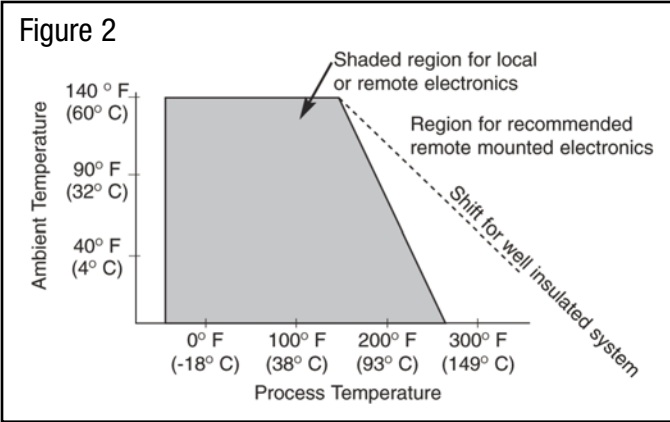

Dual signal processing technology independently measures each vortex providing increased accuracy and turndown.

Flow Meter Pressure Rating

ANSI Flange Pressure - Temperature Ratings. Maximum Pressure in psig.

TABLE 69 - FLOW METER PRESSURE RATING

MATERIAL	TEMP. °F					
	-100 to 100	200	300	400	500	600
316L SS 150# RF	230	195	175	160	145	140
316L SS 300# RF	600	505	455	415	380	360
316L SS 600# RF	1000	1000	910	825	765	720

Flow Ranges

Minimum and maximum flow rates to achieve accuracy. Pipe ID based on schedule 40 steel.

TABLE 70 - WATER FLOW RATES AT 70 °F

	4"		5"		6"		8"		10"		12"		14"	
	min	max	min	max	min	max	min	max	min	max	min	max	min	max
gal/min	119	1190.3	187	1871.6	270	2701.1	468	4675.0	737	7372.0	1047	10466.3	1265	12648.9
L/min	451	4505.6	708	7084.7	1022	10224.3	1770	17696.4	2791	27905.4	3962	39618.1	4788	47880.1

	16"		18"		20"		24"		30"		36"	
	min	max	min	max	min	max	min	max	min	max	min	max
gal/min	1652	16524.1	2091	20915.1	2599	25994.0	3760	37595.4	5965	59648.2	8740	87397
L/min	6255	62549.0	7917	79169.9	9840	98395.3	14231	142310.1	22579	225786.9	33083	330833.6



Minimum and maximum flow rates to achieve accuracy in (lb/hr).
Pipe ID based on schedule 40 steel.

TABLE 71 - SATURATED STEAM FLOW RATES AT SELECTED PROCESS PRESSURES (English)

Pressure (psig)	4"		6"		8"		10"		12"		14"		16"		18"		20"	
	min	max	min	max	min	max	min	max	min	max	min	max	min	max	min	max	min	max
10	482	4821	1094	10942	1895	18947	2986	29865	4239	42392	5124	51241	6693	66927	8472	84715	10527	105266
25	752	7517	1706	17058	2954	29539	4656	46560	6609	66090	7989	79887	10434	104342	13207	132073	16411	164114
50	1188	11883	2697	26967	4670	46696	7360	73604	10448	104479	12629	126289	16495	164949	20879	208788	25944	259440
75	1617	16168	3669	36691	6354	63535	10015	100146	14215	142154	17183	171828	22443	224429	28408	284077	35299	352993
100	2041	20407	4631	46312	8020	80195	12641	126406	17943	179430	21689	216885	28328	283279	35857	358567	45556	455555
125	2462	24619	5587	55870	9675	96746	15249	152494	21646	216461	26165	261647	34174	341742	43257	432569	53751	537510
150	2881	28813	6539	65389	11323	113228	17848	178485	25334	253340	30622	306224	39997	399966	50627	506268	62909	629087
200	3718	37177	8437	84371	14610	146098	23029	230285	32688	326883	39512	395119	51607	516074	65323	653233	81171	811707
250	4554	45540	10335	103349	17896	178961	28208	282084	40041	400411	48400	483995	63216	632157	80017	800169	99429	994289
300	5361	53612	12169	121688	21068	210683	33209	332086	47139	471388	56979	569789	74421	744214	94201	942008	117054	1170538
350	6242	62417	14141	141407	24486	244864	38596	385963	54786	547864	62223	622229	86495	864953	109484	1094836	136044	1360441
400	7104	71043	16123	161226	27918	279183	44006	440057	62465	624650	75504	755044	98618	986180	124828	1248282	155111	1551114
450	7979	79789	18107	181074	31355	313551	49223	492230	70155	701547	84799	847993	110758	1107582	140195	1401950	174206	1742061

Minimum and maximum flow rates to achieve accuracy in (kg/hr).
Pipe ID based on schedule 40 steel.

TABLE 72 - SATURATED STEAM FLOW RATES AT SELECTED PROCESS PRESSURES (English)

Pressure (bar abs)	100mm		150mm		200mm		250mm		300mm		350mm		400mm		450mm		500mm	
	min	max	min	max	min	max	min	max	min	max	min	max	min	max	min	max	min	max
1	134	1342	305	3045	527	5272	831	8310	1180	11796	1426	14259	1862	18624	2357	23574	2929	29292
2	257	2574	584	5842	1012	10116	1595	15946	2264	22635	2736	27360	3574	35735	4523	45232	5621	56206
4	493	4927	1118	11181	1936	19361	3052	30518	4332	43319	5236	52362	6839	68391	8657	86568	10757	107569
6	722	7218	1638	16380	2836	28364	4471	44708	6346	63461	7671	76709	10019	100191	12682	126819	15759	157586
10	1172	11723	2661	26605	4607	46069	7262	72616	10308	103076	12459	124593	16273	162734	20599	205985	25596	255956
14	1619	16189	3674	36739	6362	63618	10028	100276	14234	142340	17205	172052	22472	224722	28445	284447	35345	353453
18	2065	20649	4686	46861	8115	81146	12791	127905	18156	181558	21946	219458	28664	286639	36282	362821	45084	450841
22	2500	25003	5674	56742	9826	98256	15487	154874	21984	219840	26573	265730	34708	347077	43932	439321	54590	545899
26	2965	29649	6729	67286	11651	116514	18365	183653	26069	260690	31511	315109	41157	411571	52096	520956	64734	647339
28	3198	31979	7257	72574	12567	125670	19809	198086	28118	281178	33987	339873	44392	443916	56190	561898	69821	698213
30	3431	34311	7787	77866	13484	134835	21253	212531	30168	301683	36466	364658	47629	476289	60287	602874	74913	749131



Minimum and Maximum Flow Rates to achieve Accuracy in CFPM (14.7 PSIA and 70 °F).
PipeID Based on Schedule 40 Steel.

TABLE 73 - AIR FLOW RATES AT 60 °F CONDITIONS

Density (lb/ft ³)	Pressure (PSIG)	4"		6"		8"		10"		12"		14"	
		min	max	min	max	min	max	min	max	min	max	min	max
0.076	0	120	1197.9	271	2715	521	5211	821	8214	1166	11659	1409	14093
0.103	5	161	1605.3	364	3638	698	6983	1101	11007	1563	15625	1889	18887
0.128	10	201	2012.8	456	4562	876	8756	1380	13802	1959	19591	2368	23681
0.180	20	283	2827.7	641	6409	1230	12301	1939	19389	2752	27523	3327	33268
0.232	30	364	3642.6	826	8256	1585	15846	2498	24977	3545	35454	4286	42855
0.284	40	446	4457.5	1010	10103	1939	19391	3056	30564	4339	43386	5244	52443
0.336	50	527	5272.4	1195	11950	2294	22936	3615	36152	5132	51317	6203	62030
0.388	60	604	6037.3	1380	13797	2648	26481	4174	41740	5925	59249	7162	71618
0.440	70	690	6902.2	1564	15644	3003	30026	4733	47328	6718	67181	8121	81205
0.493	80	772	7717.1	1749	17490	3357	33571	5292	52915	7511	75113	9079	90792
0.545	90	853	8532.0	1934	19337	3712	37116	5850	58504	8304	83044	10038	100379
0.596	100	935	9346.9	2118	21184	4066	40661	6409	64091	9098	90976	10977	109967
0.649	110	1016	10161.8	2303	23031	4421	44206	6998	69979	9891	98907	11955	119554
0.700	120	1098	10976.7	2488	24878	4775	47751	7527	75266	10684	106839	12914	129142
0.752	130	1179	11791.6	2673	26725	5130	51296	8084	80854	11477	114771	13873	138729
0.804	140	1261	12606.5	2857	28572	5484	54841	8644	86442	12270	122703	14832	148317
0.856	150	1342	13421.4	3042	30419	5839	58386	9203	92030	13063	130634	15790	157904
1.116	200	1749	17495.9	3965	39654	7611	76111	11997	119968	17029	170293	20884	208841
1.636	300	2564	25644.8	5812	58123	11156	111560	17585	175846	24961	249609	30171	301714

Density (lb/ft ³)	Pressure (PSIG)	16"		18"		20"		24"		30"		36"	
		min	max	min	max	min	max	min	max	min	max	min	max
0.076	0	1841	18407	2330	23300	2895	28953	4187	41875	6999	69995	9738	97377
0.103	5	2467	24669	3122	31225	3880	38800	5612	56118	9380	93803	13050	130498
0.128	10	3093	30930	3915	39150	4865	48648	7037	70362	11761	117611	16362	163620
0.180	20	4345	43452	5500	55000	6834	68344	9885	98848	16523	165227	22986	229863
0.232	30	5597	55974	7085	70851	8804	88039	12733	127335	21284	212843	29611	296106
0.284	40	6850	68497	8670	86701	10773	107735	15582	155821	26046	260459	36235	362348
0.336	50	8101	81019	10255	102552	12743	127431	18431	184308	30807	308075	42860	428591
0.388	60	9354	93541	11840	118402	14713	147127	21279	212794	35569	355691	49483	494834
0.440	70	10606	106063	13425	134253	16682	166822	24128	241281	40331	403307	56108	561077
0.493	80	11859	118586	15010	150103	18652	186518	26977	269767	45092	450923	62732	627320
0.545	90	13111	131108	16595	165953	20621	206214	29825	298254	49854	498539	69350	693503
0.596	100	14363	143630	18180	181804	22591	225909	32674	326741	54615	546155	75981	759806
0.649	110	15615	156152	19765	197654	24560	245605	35523	355227	59377	593771	82605	826048
0.700	120	16869	168675	21350	213505	26530	265301	38371	383713	64139	641387	89229	892291
0.752	130	18120	181197	22935	229355	28500	284996	41220	412200	68900	689003	95853	958534
0.804	140	19372	193719	24521	245205	30470	304692	44069	440687	73662	736619	104278	1042777
0.856	150	20624	206242	26106	261056	32439	324387	46917	469173	78423	784235	109102	1091020
1.116	200	26885	268853	34037	340307	44287	442866	61161	611606	102232	1022315	142223	1422234
1.636	300	39408	394076	49881	498812	61982	619823	89647	896471	149847	1498474	208466	2084663

Flanged Insertion Meter

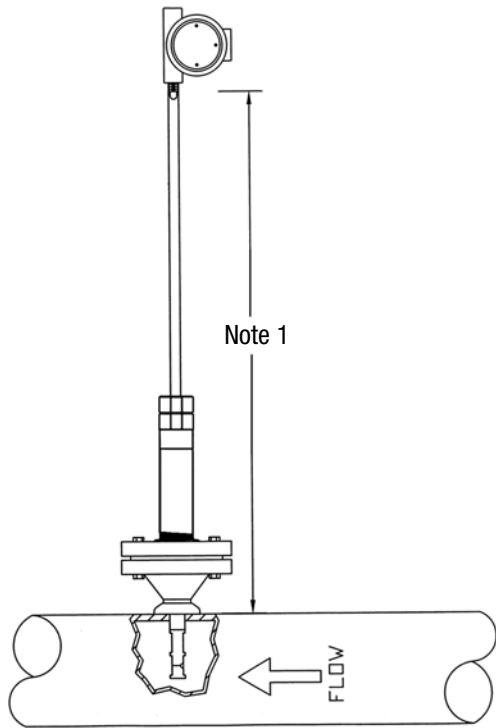

1-1/2" MNPT Insertion Meter

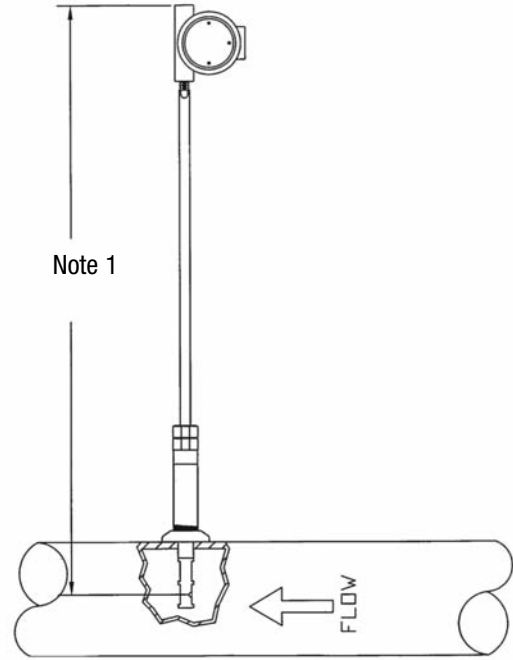

1-1/2" Insertion Meter Assembly with Insertion Tool and Ball Valve

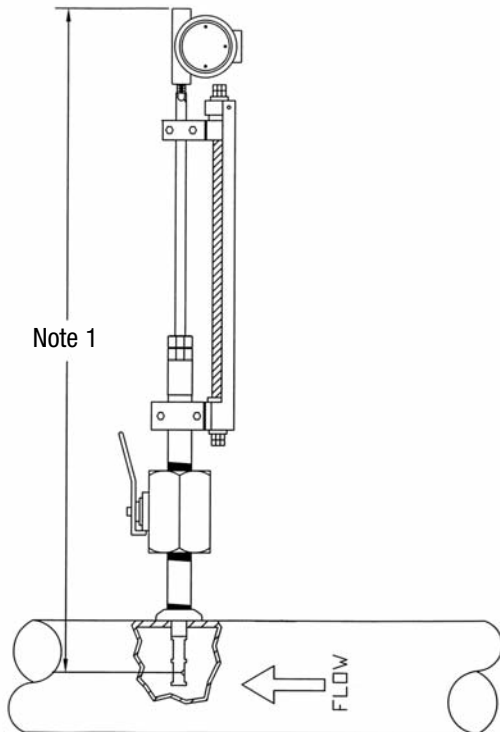

1-1/2" Welded Insertion Meter

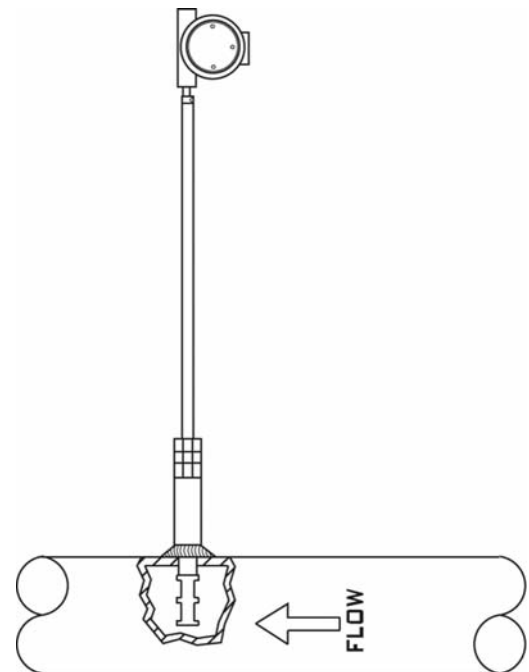

Note 1: Length dependent on pipe diameter, thickness, and mounting.



MODEL	
VX	

STYLE	
I	Insertion

SIZE: PIPE I.D. / MAX. INSERTION DEPTH *	
12	4"-24" / 12"
24	25"-36" / 18"
36	37"-72" / 24"
48	73"-144" / 36"

FLUID TYPE	
G	Gas
L	Liquid
S	Steam

MAX TEMP.	
4	450 °F
5	500 °F

MATERIAL	
6	316 SS

MOUNTING CONNECTION	
C	Insertion with Flange.
D	Insertion. With 1.5 MNPT Thread.
E	Insertion, Welded.
F	Other.

FLANGE RATING†	
A	150# ANSI RF
B	300# ANSI RF
C	600# ANSI RF
D	OTHER
N	NONE

DISPLAY	
L2	Local with RS232
R2	Remote with RS232
L4	Local with RS485
R4	Remote with RS425

POWER	
04	24VDC
12	120VAC
22	220VAC

To allow us to confirm selection please return completed application data sheet found on Aalborg's web site at www.aalborg.com.

1. Style Insertion.
2. Select meter size to match internal pipe diameter (for insertion style select pipe diameter).
3. Confirm minimum and maximum flow ranges to maintain stated accuracy from liquid, steam, or air from Tables 71 to 74 are within your requirements.
4. For other gas applications consult factory.
5. Select fluid type.
6. Select maximum temperature capability.
7. Select desired **Material of Construction.
8. Select mounting connection.
9. Confirm maximum pressure capability of flange/meter rating with process conditions and select flange rating from Table 70.
10. Confirm suitability of standard local mounted electronics.
11. Select desired transmitter power.
12. Provide: Fluid, Fluid Viscosity, Minimum & Maximum Operating Pressure, Minimum & Maximum Operating Temperature, Density/Specific Gravity or Specific Volume.
13. Provide minimum and maximum flow range.

Options: Remote mount electronics up to 100 ft. (30.5 m).

- † = Insertion Style for Alignment Ring Selection.
- * = Depends on pipe wall thickness and mounting.
- ** = The selection of materials of construction, is the responsibility of the customer. The company accepts no liability.

VX I - 12 L - 5 6 E B - L2 22

EXAMPLE: VXI-12L-54EB-L222

SPECIFY: FLUID NAME or MEASURING DENSITY, FLOW RATE, TEMPERATURE and PRESSURE (STEAM, GASES).

Vortex meter, Insertion style, 10" diameter size, Liquid at maximum 500 °F, 316 stainless steel, Insertion Welded Mounting Connection, Flange 300# ANSI RF, Local display with RS232, 220V power.



PSV Proportionating Electromagnetic Valve

PSV Proportionating Electromagnetic Valves are designed to respond to variable power inputs to proportionately regulate the flow of liquids and gases.

For added safety PSV valves are normally closed (NC) when de-energized. They can also serve as “ON-OFF” valves. For control functions see the PSV-D Driver Module.

Flow is controlled by increasing or decreasing the voltage applied to the coil. This causes a magnetic force which raises the core and allows gas to flow.

PSV valves, constructed of stainless steel are available in five different sizes covering flow ranges from 3.5 L/min - 100 L/min air and 125 mL/min - 2.85 L/min H₂O.

Design Features

- Leak Integrity 1 x 10⁻⁹ mL/min
- Rigid metallic construction
- Gas and liquids.
- Max pressure of 1000 psig (68.9 bars)

Principle of Operation

A variable stroke electromagnetic valve featuring a valve seat design which permits increasing or decreasing flow rates of liquids or gases through it in proportion to variable input power.

Regulator Systems

Complete flow regulating systems include a PSV electromagnetic valve connected to a pulse width modulated PSV-D Driver Module. For details see Driver Module description.

TABLE 74 - MAX FLOW RATES AND CV VALUES FOR PSV

MODEL NUMBER	ORIFICE SIZE		Cv	*MAXIMUM FLOW [mL/min]	
	[in]	[mm]		AIR	WATER
PSV1S-VA	0.02	0.51	0.009	3500	125
PSV2S-VA	0.04	1.02	0.033	13000	400
PSV3S-VA	0.055	1.4	0.055	21500	700
PSV4S-VA	0.063	1.6	0.068	25000	850
PSV5S-VA	0.125	3.18	0.24	100000	2850

*Based on 10 psig (690 mbar) differential pressure.

**The selection of materials of construction, is the responsibility of the customer. The company accepts no liability.

TABLE 75 - SPECIFICATIONS

POWER INPUT:	0-30Vdc.
MAXIMUM POWER REQUIRED:	400 mA.
TYPE OF OPERATION:	Normally closed (NC) when de-energized.
CONNECTIONS:	1/4" Compression fittings optional 3/8" (1/8" with PSV1, 2 or 3).
DIMENSIONS:	3.45" (87.6mm) high x 3.25" (82.6mm) long (including compression fittings) x 1.00" (25.4mm) deep.
**MATERIALS IN FLUID CONTACT:	Types 316 and 416 stainless steel, Viton® O-rings. Optional O-rings: Buna®, EPR and Kalrez®.
MAXIMUM PRESSURE:	1000 psig (6897 kPa).
MAXIMUM DIFFERENTIAL PRESSURE:	50 psid (345 kPa).
LEAK INTEGRITY:	1 X 10 ⁻⁹ smL/sec Helium individually tested.
MAXIMUM TEMPERATURE (typical):	174 °F (79 °C) inside, 130 °F (54 °C) outside surface at 24Vdc.

Pressure Drops Across PSV Valves

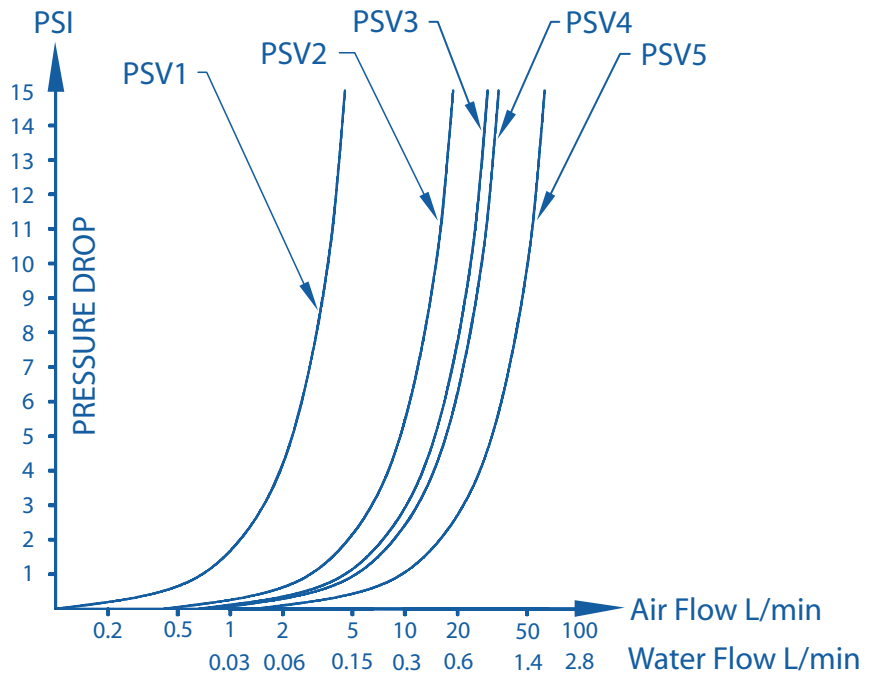

Cross Sectional View PSV Valve

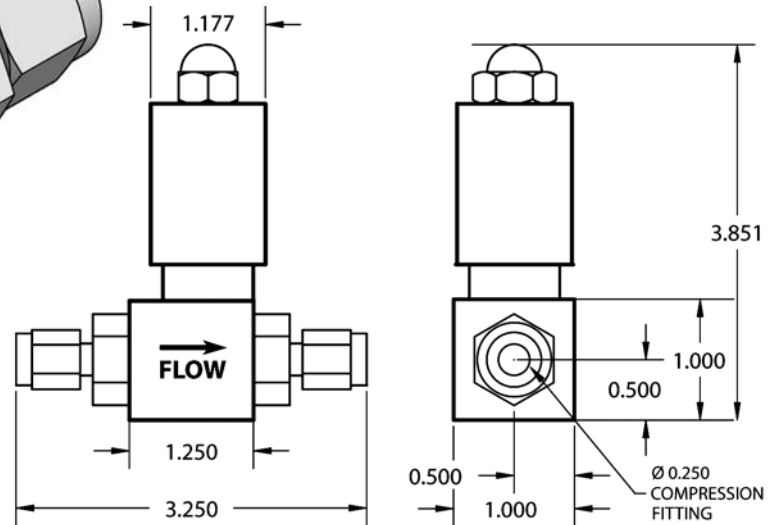
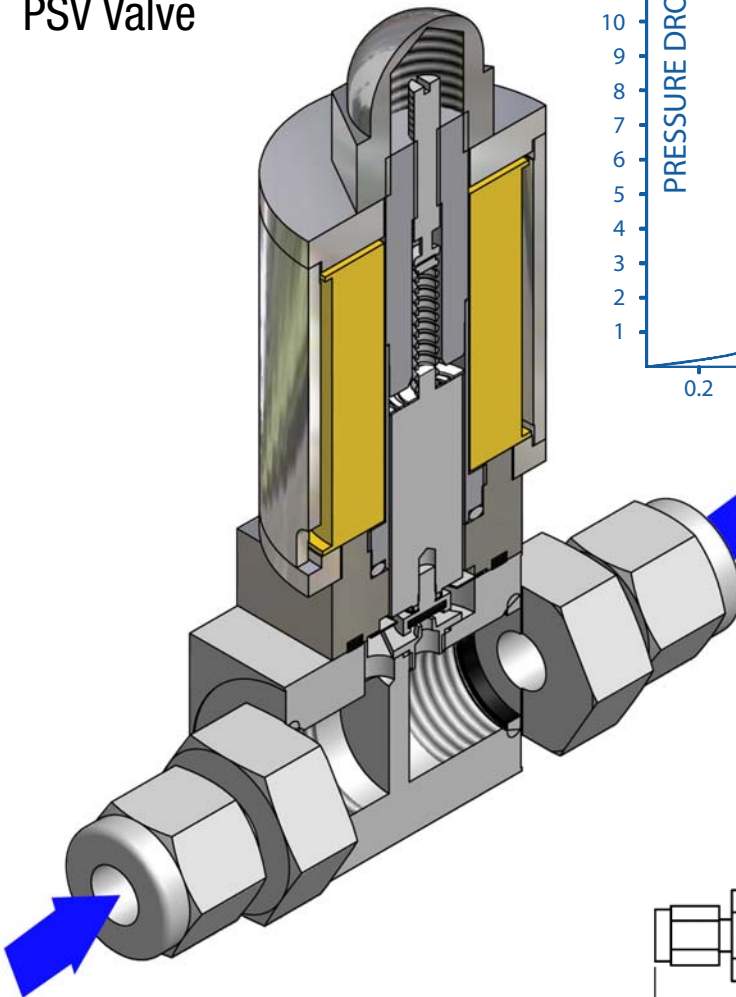

PSV Proportionating Electromagnetic Valves

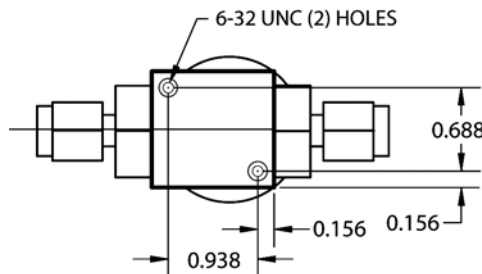

MODEL	
PSV	
SERIES	
1	
2	
3	
4	
5	
MATERIAL	
S	Stainless Steel
SEALS	
V	Viton®
B	Buna®
E	EPR
T	PTFE / Kalrez®
FITTINGS	
A	1/4" Compression
B	1/8" Compression (1/8" with PSV1, 2 or 3)
D	3/8" Compression
X	Special

PSV 4 S — V A

EXAMPLE: PSV4S-VA

PSV4 stainless steel, Viton® seals with 1/4" compression fittings.

PSV-D

Pulse width modulated PSV-D Driver Modules regulate the power supplied to PSV Regulating valves based on a reference signal.

Set-point signals, 0-5 Vdc or 4-20 mA, input are employed to control the output pulse width modulated voltage at a fixed frequency ($\approx 30\text{KHz}$) and amplitude. Incoming power to the valve coil is applied and discontinued for predetermined periods of time by a low loss solid state switching element.

As incoming power is applied, energy in the inductive coils increases and when it is discontinued energy stored in the coil maintains the magnetic flux level required to hold flow at the controlled rate. This cycle takes place many thousands of times per second.

The wide range of power input features conveniently accommodates 12 to 32 Vdc sources.

The Auto-Select feature of the Driver Module recognizes the type of reference signal received and defaults to 0 - 5 Vdc if both signals are provided.



Shown with PSV Valve

Dimensions Pulse Width Modulated Driver Module

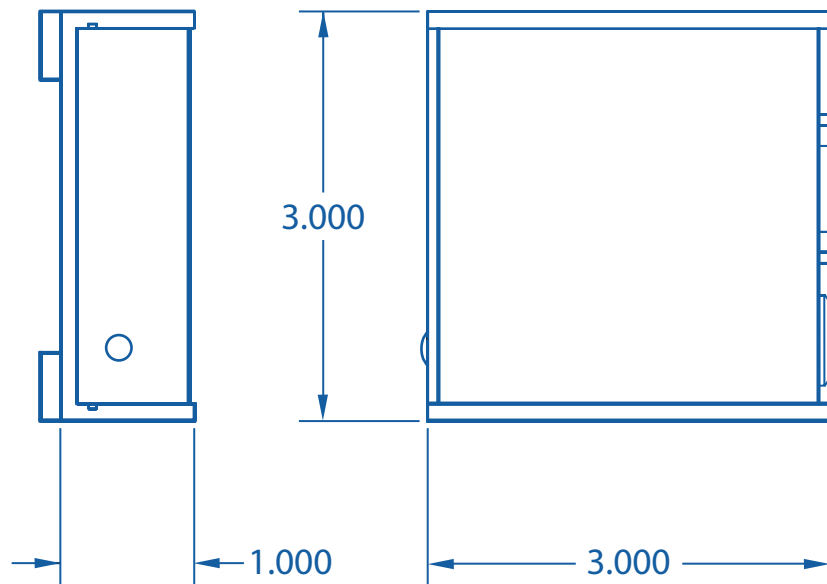

PSV-D Output vs. Flow Ranges

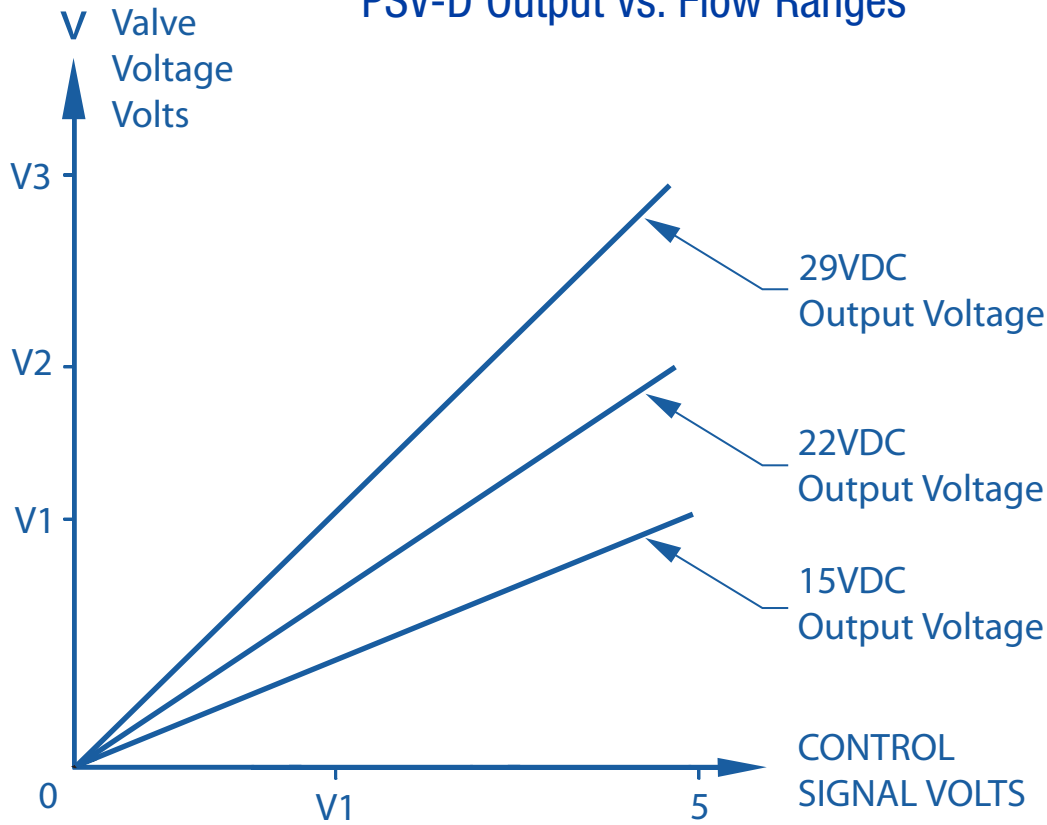

Jumper selectable output power allows a choice of dc voltage range for cooler more efficient operation, as a function of flow rates.

Internal resettable fuse protects electronics and rectifier circuits, prevents polarity reversal damage.

The maximum output voltage supplied to the PSV Valve can be set or changed in the field to allow for optimal use of the input reference signal to output voltage based on the specific flow rate and operating pressure applied to the valve.

TABLE 76 - SPECIFICATIONS

CONNECTION:	9-pin male "D" subconnector for input/output signals.
POWER INPUT REQUIRED:	+12 to 30 Vdc 1A @ 12 Vdc, 0.5A (not supplied) @ 24 Vdc via 9-pin "D"-connector or dc power jack (center positive).
INPUT SIGNAL:	Auto-Select feature allows circuit to recognize which analog input reference (0 to 5 Vdc or 4-20 mA) signal is provided.
TTL ON/OFF:	Jumper selectable LOW (0 Vdc) OFF-HIGH (5 Vdc) on, or reverse, to select valve ON/OFF status.
VALVE OUTPUT POWER:	Jumper selectable to +15, +22, and +29 Vdc with adjacent potentiometer to obtain ±2 Vdc.
FUSE RATING:	An internal resettable 1.6A fuse protects the electronics on the power input.
POLARITY PROTECTION:	Internal rectifier circuit protects from reversed polarity on the power input.
OPERATING TEMPERATURE:	32 °F (0 °C) to 122 °F (50 °C).
DIMENSIONS:	3" (7.62mm) wide x 3" (7.62mm) deep x 1" (25.4mm) high.
CE COMPLIANCE:	EMC Directive 89/336/EEC EN55011:1991 Group 1, Class A EN50082-2:1995.

ORDERING INFORMATION FOR PSV-D

MODEL	
PSV-D	Proportionating Solenoid Valve Driver
PSV-D	

TABLE 77 - ACCESSORIES FOR FOR PSVD DRIVER MODULE

PS-PSV-110NA-4	Power Supply, 110vac/24 Vdc /North America
PS-PSV-230EU-4	Power Supply, 230vac/24 Vdc /Europe
PS-PSV-240AU-4	Power Supply 240vac/24 Vdc /Australia
PS-PSV-240UK-4	Power Supply 240vac/24 Vdc /United Kingdom
CBL-DP9-6	Female 9 pin D-connector with 6 ft.cable



Design Features

- High precision two-way metering valves in aluminum or 316 SS for air/water.
- Unparalleled precision and resolution in controlling flow rates (0.00025" per step resolution standard, 0.000125" optional).
- Operate continuously without overheating.
- Eliminates coil heating problems associated with solenoid designs.

SMV Stepping Motor Valves



Dimensions SMV Stepping Motor Valves

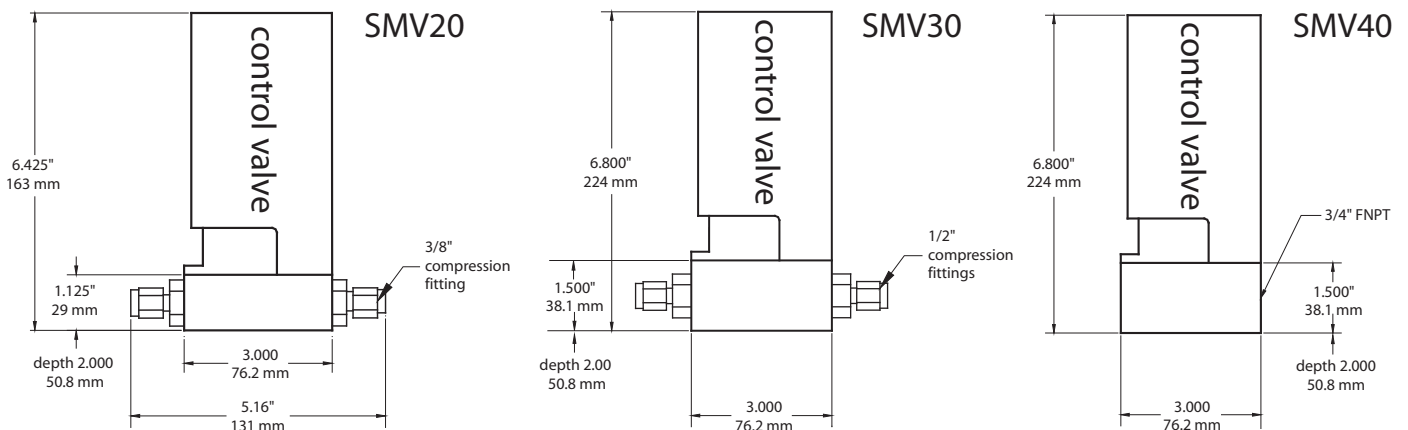

BULLETIN EM201412 SMV

TABLE 78 - SPECIFICATIONS

ALUMINUM MODELS:	Aluminum housings and valve blocks, Viton® O-Rings, PFA closing pins.
STAINLESS STEEL / PTFE MODELS:	316 stainless steel valve blocks, PTFE-lined aluminum housing blocks, Viton® O-Rings, and PFA closing pins.
MAXIMUM FLOW RATES:	1000 L/min (air), 28 L/min (H ₂ O).
CONNECTIONS:	3/8", 1/2", compression and 3/4" FNPT.
ELECTRICAL CONNECTIONS:	9-pin "D"-connector, located at the side of the valve.
POWER INPUT:	12Vdc @ 800 mA, or +24 Vdc @ 600 mA, protected by a 1600mA resettable fuse.
DIRECTIONAL CONTROL SIGNAL:	12Vdc CMOS compatible logic level signal (10K input impedance). (Logic High >= 7.5 Vdc, Low <2.3 Vdc).
SPEED CONTROL SIGNAL:	Analog 0 to 2.5 Vdc (100K input impedance). ON/OFF override: 12 Vdc CMOS low active level to pins 7 and 3 (10K input impedance).
RESPONSE TIME:	100ms time constant.
PRESSURE DROP AT MAX. FLOW:	(700 to 1000) mbars 10 to 15 psid.
MAXIMUM OPERATING PRESSURE:	500 psig (35 bars).
MAXIMUM DIFFERENTIAL PRESSURE:	40 psig (2.7 bars).
GAS & AMBIENT TEMPERATURE:	32 °F to 122 °F (0 °C to 50 °C).

Operation

When the "DIRECTION" is set LOW (GND) the valve spindle travels downward (closes), when it is set HIGH, the valve spindle moves upward (opens). The "SPEED" voltage on pin 4 determines how quickly the valve opens or closes. The signal amplitude for the "SPEED" control signal must remain within the limits of 0 to +2.5 VDC. It may be necessary to override "DIRECTION" and "SPEED" signals with the preset (2.75 Vdc) speed control signal.

This can be accomplished with valve CLOSE and PURGE control signals (open collector NPN compatible). In order to CLOSE the valve, pin 3 on the 9-pin "D"-connector has to be connected to GND (pin 2). A GREEN light on the top of the valve will indicate a CLOSED valve condition. In order to PURGE the valve, pin 7 on the 9-pin "D"-connector has to be connected to GND (pin 2). A RED light on the top of the valve will indicate a fully OPEN valve condition. During normal operation the valve remains in the last position as it is deenergized.

After powering up, the valve will be automatically closed within the first 10 seconds and after that resumes control operation. Operating power and valve control signals are supplied via the "D"-connector.

General Description

A line of electronic two-way metering needle valves is presented. High precision linear stepping motors drive the valve spindle.

The resolution of the stepping motor driven needles is 0.00025"/step. Standard optional 0.000125" /step resolution available. Low differential pressure valves, may be operated continuously (100% duty cycle). Valves stay in position as when de-energized.

Advantages over solenoid operated valves include cool operations, i.e. there are no control operating problems due to coils heating up, extremely fine resolution, very low differential pressures and high operating pressures. Valves are controllable by CMOS 12 Vdc compatible logic level and analog 0 to 2.5 Vdc signals.

TABLE 79 - FLOW RATE FOR SMV

MODEL NUMBERS	MAXIMUM FLOW RATE				Cv	CONNECTIONS	MATERIAL
	AIR		H ₂ O				
	[L/min]	[scfh]	[L/min]	gal/min			
SMV20-A	200	424	5.6	1.48	0.336	3/8" compression	Aluminum
SMV20-S	200	424	5.6	1.48	0.336	3/8" compression	Stainless Steel
SMV30-A	500	1060	14.2	3.75	0.855	1/2" compression	Aluminum
SMV30-S	500	1060	14.2	3.75	0.855	1/2" compression	Stainless Steel
SMV40-A	1000	2119	28	7.4	1.735	3/4" FNPT	Aluminum
SMV40-S	1000	2119	28	7.4	1.735	3/4" FNPT	Stainless Steel

TABLE 80 - CONVERSION FACTORS

MULTIPLY	BY	TO OBTAIN
atm	14.70	lbs/sq. in
atm	1.0333	kg/sq. cm
lbs/sq. in	0.07031	kg/sq. cm
ml/min	0.001	liters/min
ml/min	3.531 X 10 ⁻⁵	cu. ft/min
ml/min	1.585 x 10 ⁻²	gal/hr
cu. ft/hr	472	ml/min
gal/min	3785	ml/min
g/ml	62.43	lbs/cu. ft
g/ml	0.03613	lbs/cu. in
cc/min	1	mL/min
cfm (ft ³ /min)	28.31	L/min
cfm (ft ³ /min)	1.699	m ³ /hr
oz/min	29.57	mL/min

TABLE 81 - PRESSURE CONVERSION FACTORS

MULTIPLY	BY	TO OBTAIN
psi	27.71	in. H ₂ O
psi	2.036	in. Hg
psi	703.1	mm/H ₂ O
psi	51.75	mm/Hg
psi	.0703	kg/cm ²
psi	.0689	bar
psi	68.95	mbar
psi	6895	Pa
psi	6.895	kPa

TABLE 82 - TEMPERATURE

°F = (1.8 x °C) + 32
°C = (°F - 32) x 0.555
°Kelvin = °C + 273.2

TABLE 83 - LENGTH

MULTIPLY	BY	TO OBTAIN
inch	2.54	cm
inch	12	foot
ft.	0.305	meter
yard	1.914	meter
Angstrom	10 ¹⁰	meter

COMMON EQUIVALENTS AND CONVERSIONS

Approximate Common Equivalents	Conversions Accurate to Parts Per Million	THESE PREFIXES MAY BE APPLIED TO ALL SI UNITS Multiples and Submultiples
1 inch = 25 millimeter	inches X 25.4* = millimeters	1 000 000 000 000 = 10 ¹²
1 foot = 0.3 meter	feet X 0.3048* = meters	1 000 000 000 = 10 ⁹
1 yard = 0.9 meter	yards X 0.9144* = meters	1 000 000 = 10 ⁶
1 mile = 1.6 kilometers	miles X 1.603 34 = kilometers	1000 = 10 ³
1 square inch = 6.5 sq centimeters	square inches X 6.4516* = square centimeters	100 = 10 ²
1 square foot = 0.09 square meter	square feet X 0.92 903 0 = square meters	10 = 10
1 square yard = 0.8 square meter	square yards X 0.836 127 = square meters	0.1 = 10 ⁻¹
1 acre = 0.4 hectare +	acres X 0.404 686 = hectares	0.01 = 10 ⁻²
1 cubic inch = 16 cu centimeters	cubic inches X 16.3871 = cubic centimeters	0.001 = 10 ⁻³
1 cubic foot = 0.03 cubic meter	cubic feet X 0.028 316.8 = cubic meters	0.000 001 = 10 ⁻⁶
1 cubic yard = 0.8 cubic meter	cubic yards X 0.764 555 = cubic meters	0.000 000 001 = 10 ⁻⁹
1 quart (lq) = 1 liter +	quarts (lq) X 0.946 353 = liters	0.000 000 000 001 = 10 ⁻¹²
1 gallon = 0.004 cubic meter	gallons X 0.003 785 41 = cubic meters	0.000 000 000 000 001 = 10 ⁻¹⁵
1 ounce (avdp) = 28 grams	ounces (avdp) X 28.3495 = grams	0.000 000 000 000 000 001 = 10 ⁻¹⁸
1 pound (avdp) = 0.45 kilogram	pounds (avdp) X 0.453 592 = kilograms	
1 horsepower = 0.75 kilowatt	horsepower X 0.745 700 = kilowatts	
1 millimeter = 0.04 inch	millimeters X 0.039 370 1 = inchs	Prefixes
1 meter = 3.3 feet	meters X 3.280 84 = feet	tara (ter'a) T
1 meter = 1.1 yards	meters X 1.093 61 = yards	giga (ji ga) G
1 kilometer = 0.6 mile	kilometers X 0.621 371 = miles	mega (meg'a) M
1 square centimeter = 0.16 square inch	sq centimeters X 0.155 000 = square inchs	kilo (kil o) k+
1 square meter = 11 square feet	square meters X 10.7639 = square feet	hecto (hek'to) h
1 square meter = 1.2 square yards	square meters X 1.195 99 = square yards	deka (dek'a) da
1 hectare + = 2.5 acres	hectares X 2.471 05 = acres	deci (des'i) d
1 cubic centimeter = 0.06 cubic feet	cu centimeters X 0.061 623 7 = cubic inchs	centi (sen'ti) c+
1 cubic meter = 35 cubic feet	cubic meters X 35.3147 = cubic feet	milli (mil'i) m+
1 cubic meter = 1.3 cubic yards	cubic meters X 1.307 95 = cubic yards	micro (mi' kro) u+
1 liter + = 1 quart	liters X 1.056 69 = quarts (lq)	nano (nan'o) n
1 cubic meter = 250 gallons	cubic meters X 264.172 = gallons	pico (pe'ko) p
1 gram = 0.035 ounces (avdp)	grams X 0.035 274 0 = ounces (avdp)	femto (fem'to) f
1 kilogram = 2.2 pounds (avdp)	kilograms X 2.204 62 = pounds (avdp)	atto (at'to) a
1 kilowatt = 1.3 horsepower	kilowatts 1.341 02 = horsepower	

+ common term not used in S1 Source: NBS Special Pub. 304.

TRADEMARKS

Aalborg[®] is a registered trademark of Aalborg Instruments & Controls.
 Buna-N[®] is a registered trademark of DuPont Dow Elastomers.
 Kalrez[®] is a registered trademark of DuPont Dow Elastomers.

VCR[®] is a registered trademark of Swagelock Marketing Company.
 Vitor[®] is a registered trademark of DuPont Dow Elastomers.

US PATENT NUMBERS

4,862,750 and 5,561,249

NOTE: The company reserves the right to change all dimensions without notice. For certified dimensions please contact Aalborg[®] Instruments and Controls.

EUROPEAN SERVICE CENTER

Authorized service and Calibration Facility For Aalborg Products located in **Germany MTC-Aalborg***
Klosterrunsstraße 18 P.O. Box 1321 Müllheim D-79379 Germany **Telefon:** +49 (0)7631 5545
Fax:+49 (0)7631 14740 • **Web:** www.analyt-mtc.de • **E-mail:** info@analyt_mtc.de *SGS ISO9001 Certification is not applicable.

Products Manufactured By Aalborg

ROTAMETERS

Single Tube

Aluminum / Brass / Stainless • Interchangeable Glass Flow Tubes • Optional Valves

Multiple Tube

Two to Six Channels • Aluminum or Stainless

PTFE Single and Multiple Tube

Chemically Inert • 1 to 4 Channels • Interchangeable Glass Flow tubes

PTFE - PFA

Chemically Inert • Low to Medium Flow of Corrosive Liquids with PFA Flow Tube

Kits

Aluminum / Stainless / PTFE • Including Five Glass Flow Tubes and a Set of Floats

Gas Proportioners

Aluminum / Stainless • Used for Blending Two or Three Gases

Medium Range

Glass Safety Shield • Dual Air and Water Scale

Optical Sensor Switch

Non-Invasive Means for Detection of a High or Low Flow

High Flow Industrial Stainless Steel Flow Meters

Heavy Duty Stainless Steel • Direct Reading Air and Water Scales

VALVES

Barstock

Brass or Stainless • Standard or High Precision

PTFE

Chemically Inert • Needle or Metering

Proportionating Solenoid

Stainless • For Controlling Gas or Liquid Flow

• Pulse width Modulated

SMV • Stepping Motor Valve

PERISTALTIC PUMPS

Fixed RPM Pumps

Pump Heads

Tubing Pumps

Variable Speeds

Dispensing Pumps

Flexible Tubings

ELECTRONIC METERS & CONTROLLERS

Low Cost Mass Flow Meters

Aluminum or Stainless • With or Without LCD Readout

Low Cost Mass Flow Controllers

Aluminum or Stainless • With or Without LCD Readout

Mass Flow Controllers

Stainless • One to Four Channel Systems

Digital Mass Flow Controllers

Auto Zero • Totalizer • Alarms • Built in RS485

Multi Parameter Digital Mass Flow Meters

Displays Flow Pressure and Temperature

Paddle Wheel Meters

For Liquids • Optional Temperature Measurements

Vortex In-Line and Insertion Flow Meters

Steam / Liquid and Gas Service

Smart Rate / Totalizer / Signal Conditioner

LCD Keypad • RS232 / 485 • Pulse Output • Alarms